

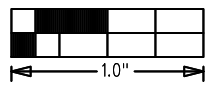

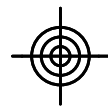

| | |
|--|-------------------------|
| MAXREFDES70# High Accuracy Flow/Heat Meter | |
| P/N: EPCBREFDES70 | REV A |
|  maxim integrated™ | |
| LAYER: TOPMIDKNSRESIDE | |
| DATE: | ALL UNITS ARE IN 0.001" |

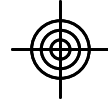
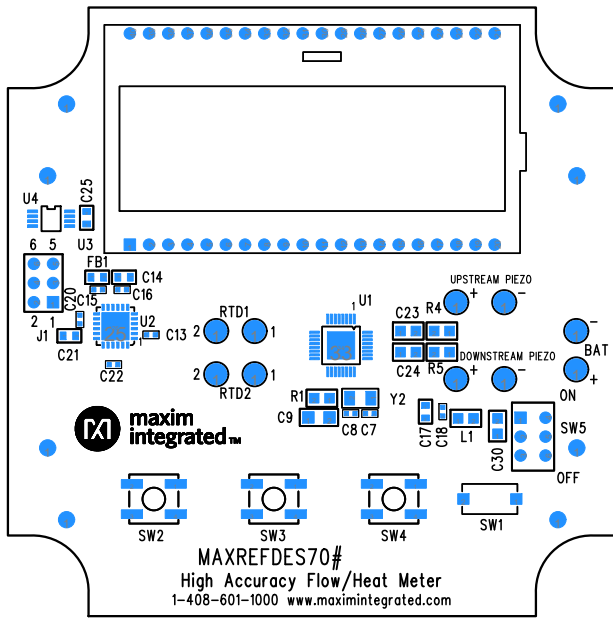

| | |
|---|-------------------------|
| MAXREFDES70# | |
| High Accuracy Flow/Heat Meter | |
| P/N: EPCBREFDES70 | REV A |
|  | |
| LAYER TOP SOLDERMASK | |
| DATE: | ALL UNITS ARE IN 0.001" |

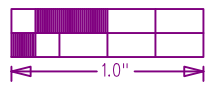
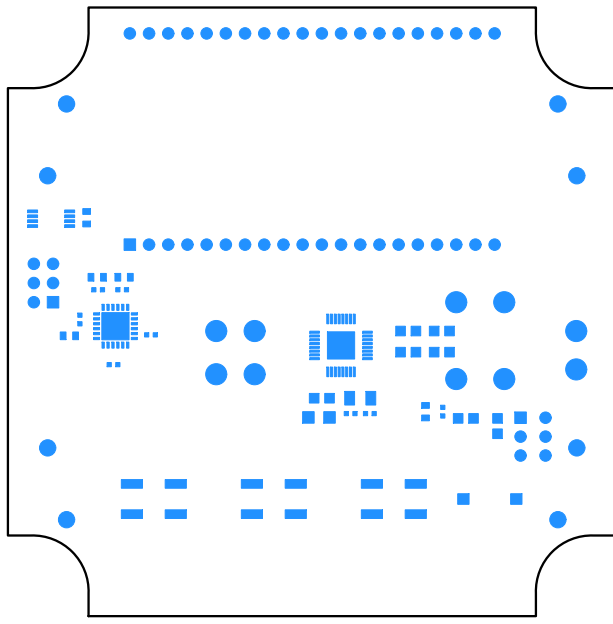

| | |
|---|-------------------------|
| MAXREFDES70# | |
| High Accuracy Flow/Heat Meter | |
| P/N: EPCBREFDES70 | REV A |
|  | |
| LAYER COMPONENT SIDE | |
| DATE: | ALL UNITS ARE IN 0.001" |

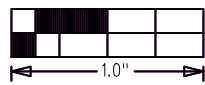
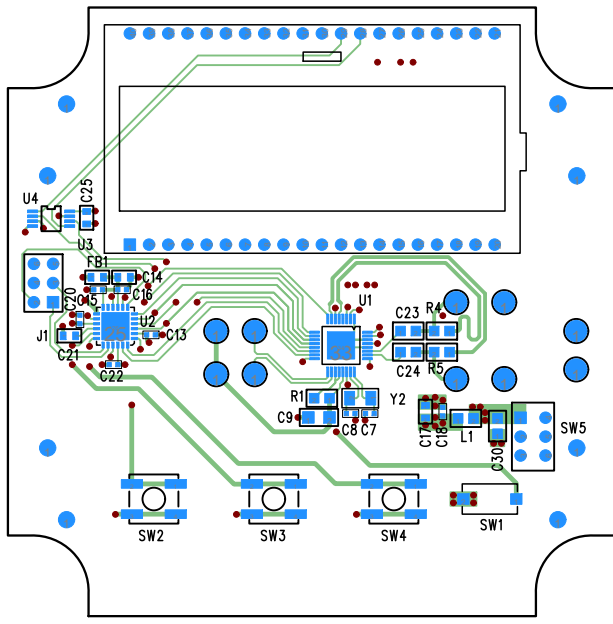

| | |
|---|-------------------------|
| MAXREFDES70# | |
| High Accuracy Flow/Heat Meter | |
| P/N: EPCBREFDES70 | REV A |
|  | |
| LAYER | LAYER 2 GND |
| DATE: | ALL UNITS ARE IN 0.001" |

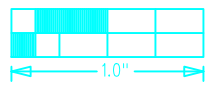
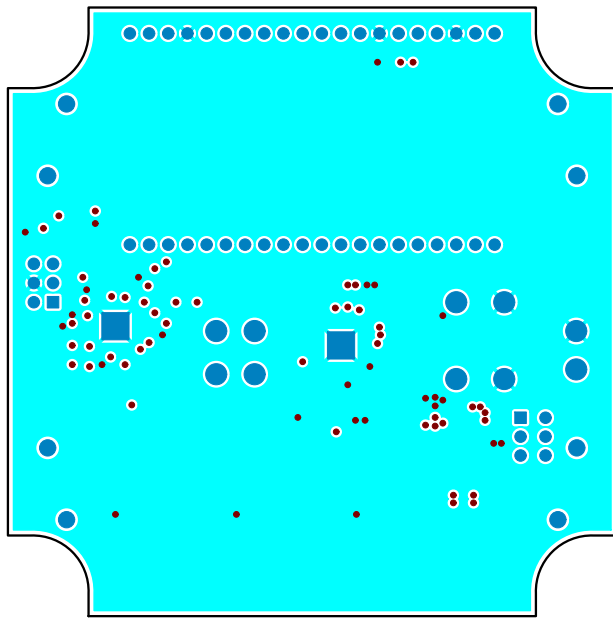

| | |
|---|-------------------------|
| MAXREFDES70# | |
| High Accuracy Flow/Heat Meter | |
| P/N: EPCBREFDES70 | REV A |
|  | |
| LAYER LAYER 3 PWR | |
| DATE: | ALL UNITS ARE IN 0.001" |

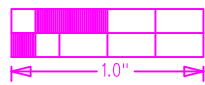
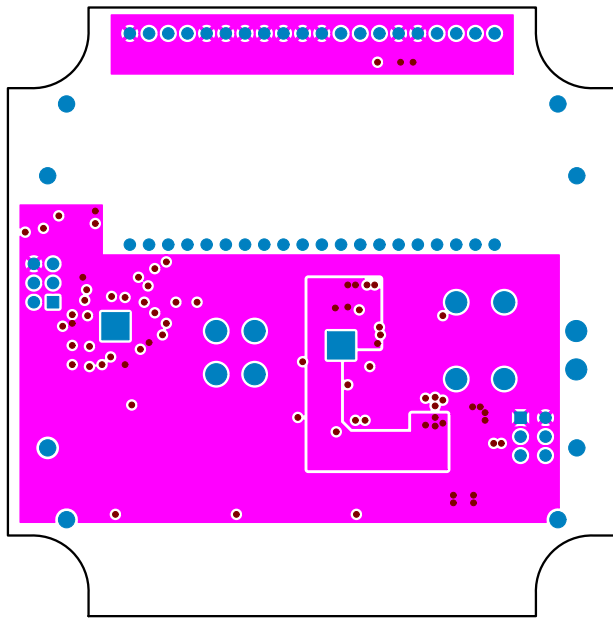

| | |
|---|-------------------------|
| MAXREFDES70# | |
| High Accuracy Flow/Heat Meter | |
| P/N: EPCBREFDES70 | REV A |
|  | |
| LAYER | SOLDER SIDE |
| DATE: | ALL UNITS ARE IN 0.001" |

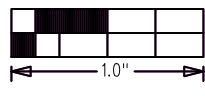
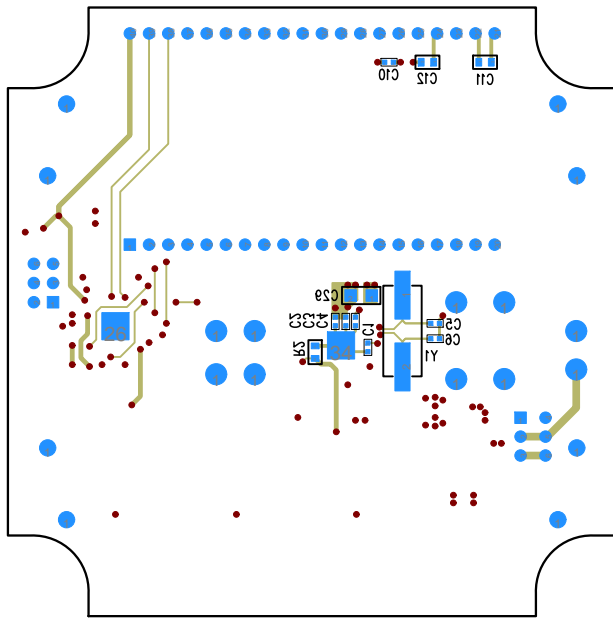

| | |
|---|-------------------------|
| MAXREFDES70# High Accuracy Flow/Heat Meter | |
| P/N: EPCBREFDES70 | REV A |
|  | |
| LAYER BOTTOM SOLDERMASK | |
| DATE: | ALL UNITS ARE IN 0.001" |

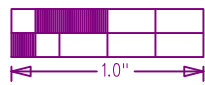
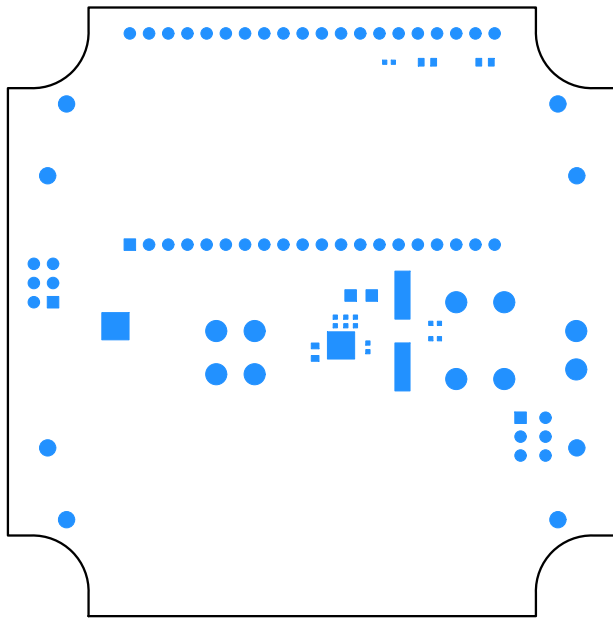

| | |
|---|-------------------------|
| MAXREFDES70# | |
| High Accuracy Flow/Heat Meter | |
| P/N: EPCBREFDES70 | REV A |
|  | |
| LAYER | SOLDER MASK SILKSCREEN |
| DATE: | ALL UNITS ARE IN 0.001" |

