



承 认 书

APPROVAL SHEET

客户名称:

Customer

/

产品名称:

Part Name

绕线型片式电感器

Wire Wound Chip inductor

产品规格:

Specification

FHD0402IF Series

版本号:

Version No.

22.01

日期:

DATE

2022-3-15

制造 Manufacturer			客户 Customer		
拟制 Draft by	审核 Checked by	确认 Approve by	检验 Check by	审核 Checked by	批准 Approval by
林晓华	徐雪枫	区军沛			



序号 No	目 录 TABLE OF CONTENTS
1	外形尺寸与内部结构 Dimension & Inner-configuration
2	产品品名构成 Product Spec. Model
3	电性能参数表 Electrical Characteristics List
4	可靠性试验项目 Reliability Testing Items
5	产品包装 Packaging
6	推荐焊接条件 Recommend Soldering Conditions
7	清洗 Cleaning
8	存储要求 Storage Requirements
9	ODS (消耗臭氧层物质) 的使用情况 Usage Of ODS
10	注意事项 Notes



1 外形尺寸与内部结构 Dimension & Inner-configuration :

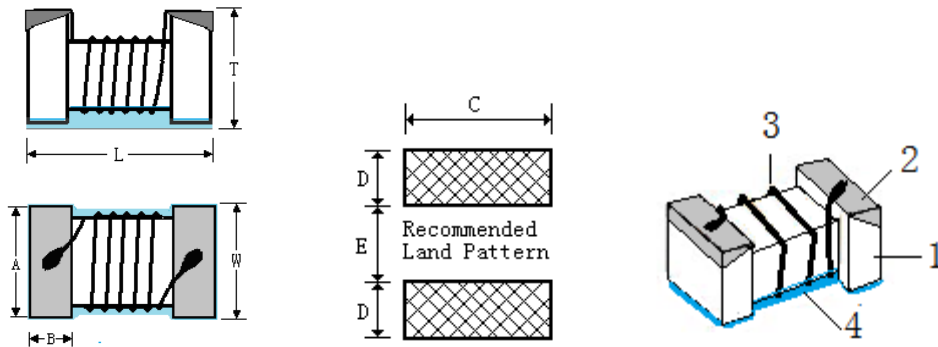

序号 No.	部位 Component	材料 Material								
1	磁芯 Core	铁氧体芯电感 Ferrite Core : 镍锌铁氧体 Ni-Zn ferrite								
2	电极 Electrode	<table border="1"> <thead> <tr> <th>分类 Type</th> <th>底层 Layout 0</th> <th>中层 Layout 1</th> <th>表层 Layout 2</th> </tr> </thead> <tbody> <tr> <td>铁氧体芯电感 Ferrite core</td> <td>银 Ag</td> <td>镍 Ni</td> <td>锡 Sn</td> </tr> </tbody> </table>	分类 Type	底层 Layout 0	中层 Layout 1	表层 Layout 2	铁氧体芯电感 Ferrite core	银 Ag	镍 Ni	锡 Sn
		分类 Type	底层 Layout 0	中层 Layout 1	表层 Layout 2					
铁氧体芯电感 Ferrite core	银 Ag	镍 Ni	锡 Sn							
3	漆包线 wire	铜 Cu								
4	封装层 encapsulation layer	树脂 UV Adhesive								

单位 Unit : mm (inch)

型号 Size	L (Max)	W (Max)	T (Max)	A	B	C	D	E
1005(0402)	1.19(0.047)	0.66(0.026)	0.60(0.024)	0.50(0.020)	0.23(0.009)	0.66(0.026)	0.36(0.014)	0.46(0.018)

2 产品品名构成 Product Spec. Model

FHD 0402 UC R10 J S T

① ② ③ ④ ⑤ ⑥ ⑦

- ① 绕线型片式电感器系列 Wire Wound Inductor Series;
- ② 外形尺寸 Dimensions: 0402、0603;
- ③ 芯片类型 Material: IF---铁氧体芯 Ferrite core;
- ④ 标称电感量 Inductance: 010=10nH、R10=100nH、1R0=1.0μH、100=10μH
- ⑤ 标称电感值偏差 Tolerance: J---±5%; K---±10%; M---±20%;
- ⑥ 电极表面镀层材料 Terminal: S---锡端头 Tin;
- ⑦ 包装类型 Packaging type: T---卷带盘装 Tape & Reel。



4 可靠性试验项目 Reliability Testing Items

序号 No.	项目 Items	要求 Requirements	试验方法及备注 Test Methods and Remarks
1	试验用标准条件 Test Standard Conditions	<p>①、除非另有规定，所有试验和测量在下述条件进行。Unless otherwise specified, all tests and measurements shall be carried out in the following conditions.</p> <p>a) 温度 Temperature: 15°C~+35 °C; b) 相对湿度 Relative humidity: 25%~75%; c) 气压 pressure: 86 kPa~106 kPa。</p> <p>②、在上述条件下测定有异议发生场合，按下述条件进行。Under the above conditions, the conditions for the determination of dissension shall be conducted according to the following conditions.</p> <p>a) 温度 Temperature: 20°C±1°C; b) 相对湿度 Relative humidity: 63%~67%; c) 气压 pressure: 86 kPa~106 kPa。</p>	
2	工作温度范围 Operating Temperature Range	① FHD-IF series: -40~+85°C	/
3	可焊性 Solder ability	<p>①外观无可见损伤痕迹; No visible mechanical damage.</p> <p>②端电极表面焊锡覆盖率。 Electrode surface solder coverage. FHD-IF series: ≥80%。</p>	<p>在 245±5°C 熔融的焊锡 (96.5%Sn/ 3.0%Ag/0.5%Cu) 中浸置 5±1s。 Dip pads in flux and dip in solder pot(96.5Sn/3.0Ag/0.5Cu)at 245±5°C for 5±1s.</p>
4	耐焊接热 Resistance to Soldering	<p>①外观无可见损伤痕迹; No visible mechanical damage.</p> <p>②感量变化不超过±5%; Inductance shall not change more than ±5%;</p>	<p>在 260±5°C 熔融的焊锡 (96.5%Sn/ 3.0%Ag/0.5%Cu) 中浸置 10±1s。 Dip pads in flux and dip in solder pot(96.5Sn/3.0Ag/0.5Cu)at 260±5°C for 10±1s.</p>

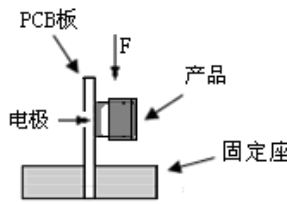

序号 No.	项目 Items	要求 Requirements	试验方法及备注 Test Methods and Remarks								
5	振动 Vibration	①外观无可见损伤痕迹; No visible mechanical damage. ②感量变化不超过±5%; Inductance shall not change more than ±5%;	振幅 1.5mm, 频率 10~55Hz, 每个方向 (X、Y、Z) 保持 2 小时。Inductors shall be subjected to vibration of 1.5mm amplitude frequency 10~55Hz (10Hz to 55Hz to 10Hz in a period of 1 minute) for 2h in each of three(X、Y、Z) axes.								
6	端电极强度 Adhesion of electrode	①试验后端电极无脱落; The end electrode did not fall off after the test. ②外观无可见损伤痕迹。 No visible mechanical damage.	将产品焊在 PCB 板上, 按下图、表所示方向及要求施加作用力。Weld the product on the PCB board, and apply force as shown in the diagram, direction and requirement.  <table border="1" data-bbox="989 1153 1460 1344"> <tr> <td>尺寸规格 Size</td> <td>施加力要求</td> </tr> <tr> <td>0402IF Series</td> <td>3 N</td> </tr> <tr> <td colspan="2">Keep time: (10±1)s</td> </tr> <tr> <td colspan="2">Speed: 1.0 mm/s.</td> </tr> </table>	尺寸规格 Size	施加力要求	0402IF Series	3 N	Keep time: (10±1)s		Speed: 1.0 mm/s.	
尺寸规格 Size	施加力要求										
0402IF Series	3 N										
Keep time: (10±1)s											
Speed: 1.0 mm/s.											
7	耐低温 Low temperature resistance	①外观无可见损伤痕迹; No visible mechanical damage. ②感量变化不超过±5%; Inductance shall not change more than ±5%.	①FHD-IF 系列产品放置于温度-40±2℃的环境中 +24 存放 1000 -0 h FHD-IF series shall be subjected to -40±2℃ +24 for 1000 -0 h								



序号 No.	项目 Items	要求 Requirements	试验方法及备注 Test Methods and Remarks
8	耐高温 High temperature resistance	①外观无可见损伤痕迹; No visible mechanical damage. ②感量变化不超过±5%; Inductance shall not change more than ±5%.	①FHD-IF 系列产品放置于温度+85±5℃的环境中 +24 存放 1000 -0 h FHD-IF series shall be subjected to +85±5℃ for +24 1000 -0 h
9	温度冲击 Temperature Shock	①外观无可见损伤痕迹; No visible mechanical damage. ②感量变化不超过±5%; Inductance shall not change more than ±5%.	①FHD-IF 系列: +85℃ 30 分钟 ↔ -40℃ 30 分 钟, 循环 100 次; FHD-IF series: +85℃ 30minutes ↔ -40℃ 30minutes 100 Cycles.
10	高温负载 High temperature load	①外观无可见损伤痕迹; No visible mechanical damage. ②感量变化不超过±5%; Inductance shall not change more than ±5%.	①FHD-IF 系列产品加额定电流在 85±2℃温度条件 +24 下存放 1000 -0 h FHD-IF series shall be store at 85±2℃ for +24 1000 -0 h with rated current applied.

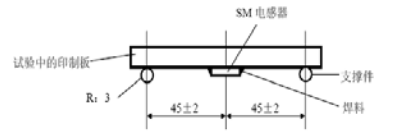
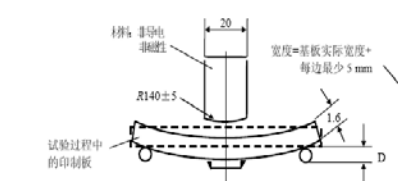

序号 No.	项目 Items	要求 Requirements	试验方法及备注 Test Methods and Remarks
11	恒定湿热 Static Humidity	①外观无可见损伤痕迹; No visible mechanical damage. ②感量变化不超过±5%; Inductance shall not change more than ±5%.	将电感器放置在于湿度 90%~95%,温度 60±2℃的 +24 环境中存放 1000—0 h Inductors shall be subjected to 90%~95%RH. at +24 60±2℃ for 1000—0 h
12	抗弯强度 Bending strength	外观无可见损伤痕迹; No visible mechanical damage.	①将电感器安装于试验基板上; 在垂直方向施加力 (如下图示)。Install the inductor on the test substrate; Apply force in the vertical direction (as shown below). ②该板应在 (1±0.5) mm/s 的弯曲速率向下弯曲 (2±0.2) mm, 保持时间 (20±1) s。The epoxy plate should bend down to (2±0.2) mm at the bending rate of (1±0.5) mm/s, Keep time (20±1) sec. 单位为毫米 安装  试验 
13	耐溶剂性 Solvent Resistance	①外观无可见损伤痕迹; No visible mechanical damage. ②感量变化不超过±5%; Inductance shall not change more than ±5%.	将元件浸泡在 23±5℃的异丙醇溶液中, 保持 5±0.5 分钟。 Soak in the element 23±5℃ in isopropyl alcohol solution, keep 5±0.5 min.

注: 以上要求测试电性能的项目, 在室温下放置至少 2 h 后在 48 h 内进行测试。

Note: When there are questions concerning, test within 48 h after placing at room temperature for at least 2 h.



5 产品包装 Packaging

1) 编带图 Taping drawings

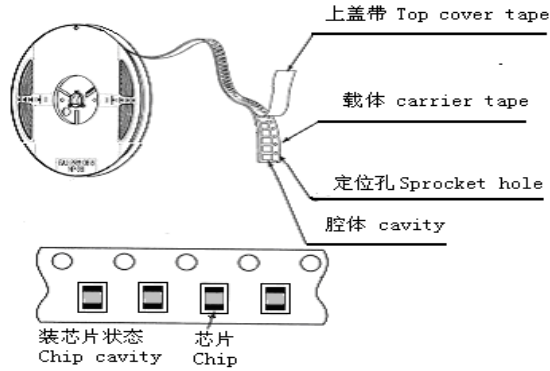

2) 卷盘尺寸 Reel dimensions (Unit: mm)

Part NO.	ΦA typ.	ΦB typ.	ΦC typ.	D typ.
0402	178	60	13	8.4

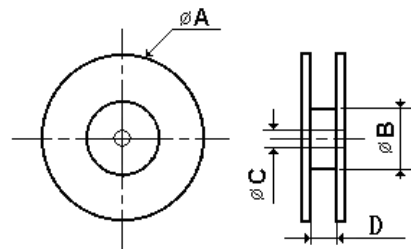

3) 导带及空格部分 Leader and blank portion

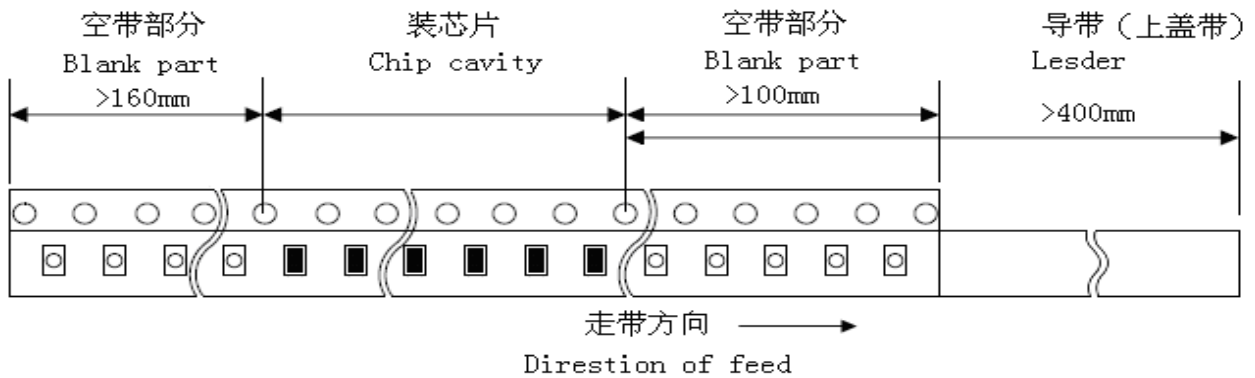

4) 编带尺寸 Taping dimensions (Unit: mm)

- 纸带 Paper tape

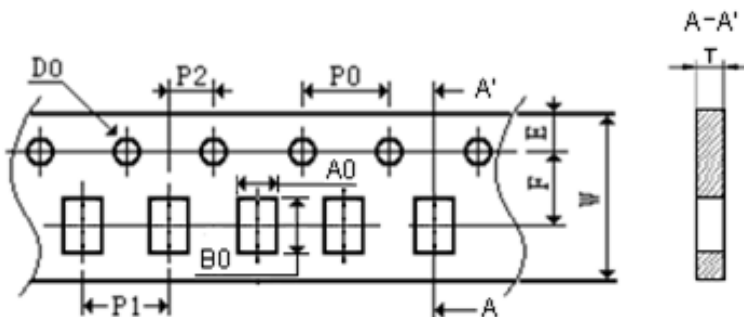



Part NO.	W	E	F	D0	P0	P1	P2	P0×10	A0	B0	T
0402	8.00	1.75	3.50	1.55	4	2	2	40	0.66	1.20	0.75

5) 剥离力检验 Peeling off force

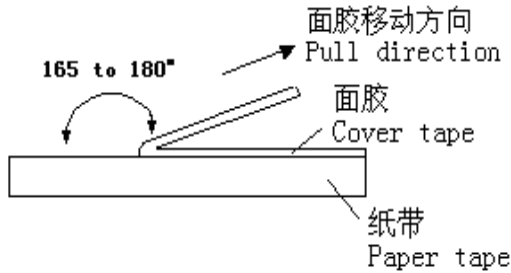

①盖带的剥离力要求 Peeling required

0402 系列 : 20 克~80 克 ;

0402 series : 20g~80g ;

②测试条件 Test condition

盖带剥离速度: 300mm/min±10%

Speed of peeling off : 300mm/min±10%

盖带剥离角度: 165° ~180°

Angle of peeling off: 165°~180°

6) 包装数量 (单位: 粒) Packaging number (Unit: Pcs)

类型 Size		0402
每卷数量 Per Reel		5000
每盒数量 Per Box	3 卷盒 3 Reel Per Box	15000
	5 卷盒 5 Reel Per Box	25000
每箱数量 Per Case	1.5 盒箱 1.5 Box Per Case	75000
	2 盒箱 2 Box Per Case	100000
	3 盒箱 3 Box Per Case	150000
	4 盒箱 4 Box Per Case	200000
	6 盒箱 6 Box Per Case	300000

7) 标签粘贴位置 Label stick station

卷盘标签 Reel label	纸盒标签 Carton label	纸盒标签 Carton label	外箱标签 Outer box label



6 推荐焊接条件 Recommend Soldering Conditions

1) 焊接条件 Soldering Conditions

本产品使用回流焊接法。

Applicable soldering process to the products is reflow soldering.

① 焊剂要求 Flux, Solder

- 使用松香基助焊剂，禁止使用卤化物含量超过 0.2(wt)% 的强酸性助焊剂。
Don't use highly acidic flux with halide content exceeding 0.2(wt)%(chlorine conversion value).
- 使用无铅焊料 (96.5Sn /3.0Ag/0.5Cu)。
Using lead-free solder (96.5Sn /3.0Ag/0.5Cu).

② 焊接要求 Soldering conditions

- 预热时，产品表温与焊料温度的温差最大不允许超出 150℃，焊接完冷却时，产品表温与溶剂温度之间的温差最大不超过 100℃。预热不足有可能引发产品表面裂纹，从而导致产品品质下降。
Pre-heating should be in such a way that the temperature difference between solder and ferrite surface is limited to 150℃ max. Also cooling into solvent after soldering should be in such way that the temperature difference is limited to 100℃ max. Un-enough pre-heating may cause cracks on the ferrite, resulting in the deterioration of product quality.
- 产品要在以下画出的曲线允许的范围进行焊接。其它焊接条件可能引起产品电极的腐蚀。当焊接重复时，允许的时间为第一次做的累计时间。
Products should be soldered within the following allowable range indicated by the slanted line. The excessive soldering conditions may cause the corrosion of the electrode. When soldering is repeated, allowable time is the accumulated time.

2) 回流焊曲线 Reflow soldering profile

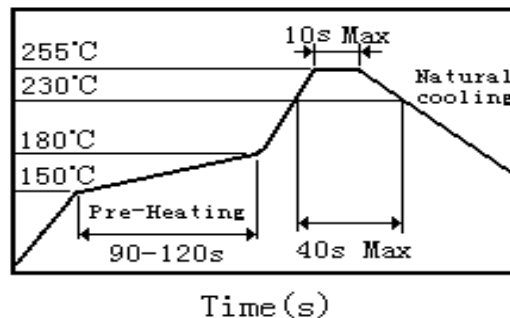

3) 手工焊接 Iron soldering

烙铁温度：350℃ (Max)

功率：最大为 30W

烙铁停留时间：<5S (注意不要将烙铁碰到产品线圈及包封层)。

Perform soldering at 350℃ on 30W max.

Soldering Time: < 5S (Take care not to apply the tip of the soldering iron to the terminal electrodes)。

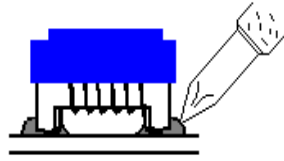

7 清洗 Cleaning

1) 清洗条件 Cleaning Conditions

- a. 清洗温度 : 60℃ (Max) Cleaning temperature : 60℃ max.
- b. 清洗时间 : 5 分钟 (Max) Cleaning time: 5 minutes Max.
- c. 超声波功率: 最大为 200W Ultrasonic output power: 200W max.

8 存储要求 Storage Requirements

1) 存储期限 Storage period

距电感公司出厂检验时间 1 年内, 产品可以使用检验时间可以通过包装外侧标记的检验号确认。若时间超过 1 年, 应检查焊接性能后方可使用。

Products which inspected inductor company over 1 year ago should be examined and used, which can be Confirmed with inspection No. marked on the container. Solder ability should be checked if this period is exceeded.

2) 存储条件 Storage conditions

- (1) 存放货物的库房应满足以下条件: 温度: -10 ~ +40℃, 相对湿度: 30 ~ 70%。
- (2) 禁止将产品保管在腐蚀性物质中, 如硫磺、氯气或酸, 否则将引起端头氧化, 导致降低焊接性。
- (3) 为了避免受潮气、灰尘等物质的影响, 产品应保管于货架上。
- (4) 产品保管在库房中, 应避免热冲击、振动以及直接光照等等。
- (5) 产品应密封包装。

(1) Products should be storage in the warehouse on the following conditions:

Temperature : -10~+40℃ Humidity: 30~70% relative humidity

- (2) Don't keep products in corrosive gases such as sulfur, chlorine gas or acid , or it may case oxidization of Electrodes resulting in poor solder ability.
- (3) Products should be stored on the palette for the prevention of the influence from humidity, dust and so on.
- (4) Products should be stored in the warehouse without heat shock, vibration, direct sunlight and so on.
- (5) Products should be stored under the airtight packaged condition.

9 ODS (消耗臭氧层物质) 的使用情况 Usage Of ODS

对于以下所列物质, 我公司在生产过程中绝不使用。

ODS: CCl₄ (四氯化碳)、HCFC 等。

For ODS listed below , we don't use in process.



ODS: CCl₄, HCFC, etc.

10 注意事项 Notes

(1) RoHS 指令 Response to RoHS directive

本公司产品符合 RoHS 指令。

Our products are RoHS compliance.

(2) 本承认书保证我司产品作为一个单体时的质量情况，当我司产品被安装到贵司产品上时请保证贵司的产品已根据贵司的规范进行了有效评价和确认。

This product specification guarantees the quality of our product as a single unit, Please make sure that your product has been evaluated and confirmed against your specifications when our product is mounted to your product.

(3) 如果贵司对我司产品的试用已超过了本测试规范所界定的产品功能，对于此所引发的失效我司将不予保证。

We can't warrant against failure caused by any use of our product that deviates from the intended use as described in this product specification.

(4) 为防止断线，请不要使用锋利的物体接触线圈，如镊子。

Do not touch wire with sharp objects such as tweezers to prevent wire breakage.



承 认 书

APPROVAL SHEET

客户名称:

Customer

/

产品名称:

Part Name

绕线型片式电感器

Wire Wound Chip inductor

产品规格:

Specification

FHD0402UC Series

版本号:

Version No.

22.01

日期:

DATE

2022-3-15

制造 Manufacturer			客户 Customer		
拟制 Draft by	审核 Checked by	确认 Approve by	检验 Check by	审核 Checked by	批准 Approval by
林晓华	徐雪枫	区军沛			



序号 No	目 录 TABLE OF CONTENTS
1	外形尺寸与内部结构 Dimension & Inner-configuration
2	产品品名构成 Product Spec. Model
3	电性能参数表 Electrical Characteristics List
4	可靠性试验项目 Reliability Testing Items
5	产品包装 Packaging
6	推荐焊接条件 Recommend Soldering Conditions
7	清洗 Cleaning
8	存储要求 Storage Requirements
9	ODS (消耗臭氧层物质) 的使用情况 Usage Of ODS
10	注意事项 Notes



1 外形尺寸与内部结构 Dimension & Inner-configuration :

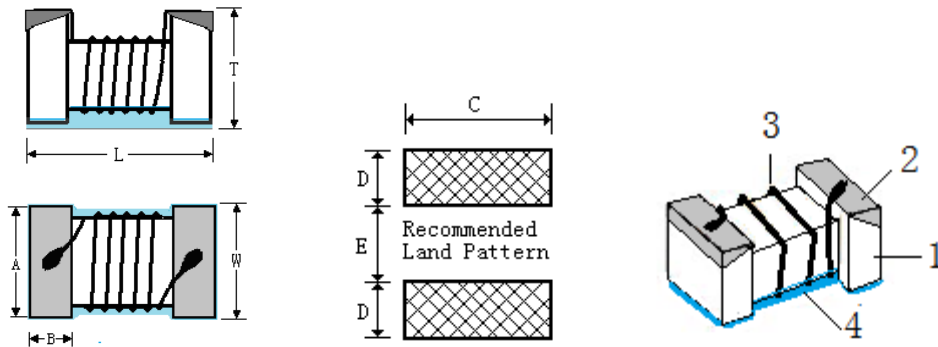

序号 No.	部位 Component	材料 Material								
1	瓷芯 Core	陶瓷芯电感 Ceramic Core : 陶瓷体 Al_2O_3								
2	电极 Electrode	<table border="1"> <thead> <tr> <th>分类 Type</th> <th>底层 Layout 0</th> <th>中层 Layout 1</th> <th>表层 Layout 2</th> </tr> </thead> <tbody> <tr> <td>陶瓷芯电感 Ceramic core</td> <td>钨或钼锰或银/银钯 W or Mo-Mn or Ag/Ag-Pd</td> <td>镍 Ni</td> <td>锡 Sn</td> </tr> </tbody> </table>	分类 Type	底层 Layout 0	中层 Layout 1	表层 Layout 2	陶瓷芯电感 Ceramic core	钨或钼锰或银/银钯 W or Mo-Mn or Ag/Ag-Pd	镍 Ni	锡 Sn
分类 Type	底层 Layout 0	中层 Layout 1	表层 Layout 2							
陶瓷芯电感 Ceramic core	钨或钼锰或银/银钯 W or Mo-Mn or Ag/Ag-Pd	镍 Ni	锡 Sn							
3	漆包线 wire	铜 Cu								
4	封装层 encapsulation layer	树脂 UV Adhesive								

单位 Unit : mm (inch)

型号 Size	L (Max)	W (Max)	T (Max)	A	B	C	D	E
1005(0402)	1.19(0.047)	0.66(0.026)	0.60(0.024)	0.50(0.020)	0.23(0.009)	0.66(0.026)	0.36(0.014)	0.46(0.018)

2 产品品名构成 Product Spec. Model

FHD 0402 UC R10 J S T

① ② ③ ④ ⑤ ⑥ ⑦

- ① 绕线型片式电感器系列 Wire Wound Inductor Series;
- ② 外形尺寸 Dimensions: 0402;
- ③ 芯片类型 Material: UC---陶瓷芯 Ceramic core;
- ④ 标称电感量 Inductance: 1N0=1.0nH、010=10nH、R10=100nH
- ⑤ 标称电感值偏差 Tolerance: B \pm 0.1nH; C \pm 0.2nH; D \pm 0.5nH; G--- \pm 2%; H--- \pm 3%; J--- \pm 5%; K--- \pm 10%;
- ⑥ 电极表面镀层材料 Terminal: S---锡端头 Tin;
- ⑦ 包装类型 Packaging type: T---卷带盘装 Tape & Reel.

3 电性能参数表 Electrical Characteristics List



型号规格 Part NO.	客户料号 Customer P/N	精度级别 accuracy grade	标称感量 Inductance (nH)	感量测试频率 Ls Test frequency (MHz)	Q 值 (Min)	Q 值测试频率 Test frequency (MHz)	直流电阻 Rdc (Ω) max	测试电压 Test voltage (mV)	自谐振频率 SRF (MHz)min	额定电流 Idc (mA)max
FHD0402UC1N0□ST		B, C, S, D, K	1.0	250	13	250	0.045	500	10000	1360
FHD0402UC1N2□ST		B, C, S, D, K	1.2	250	8	250	0.135	500	10000	640
FHD0402UC1N8□ST		C, S, D, K	1.8	250	16	250	0.070	500	6000	1040
FHD0402UC1N9□ST		C, S, D, K	1.9	250	16	250	0.070	500	6000	1040
FHD0402UC2N0□ST		C, S, D, K	2.0	250	18	250	0.070	500	6000	1040
FHD0402UC2N2□ST		C, S, D, K	2.2	250	18	250	0.070	500	6000	960
FHD0402UC2N4□ST		C, S, D, K	2.4	250	16	250	0.080	500	6000	790
FHD0402UC2N5□ST		C, S, D, K	2.5	250	15	250	0.120	500	6000	640
FHD0402UC2N7□ST		C, S, D, K	2.7	250	15	250	0.120	500	6000	640
FHD0402UC2N9□ST		C, S, D, K	2.9	250	8	250	0.300	500	6000	400
FHD0402UC3N3□ST		C, S, D, J, K	3.3	250	20	250	0.066	500	6000	840
FHD0402UC3N6□ST		B, C, S, D, J, K	3.6	250	20	250	0.066	500	6000	840
FHD0402UC3N9□ST		B, C, S, D, J, K	3.9	250	20	250	0.066	500	6000	840
FHD0402UC4N3□ST		C, S, D, J, K	4.3	250	20	250	0.091	500	6000	700
FHD0402UC4N7□ST		B, C, S, D, J, K	4.7	250	18	250	0.200	500	4500	640
FHD0402UC5N1□ST		B, C, S, D, J, K	5.1	250	18	250	0.083	500	4800	800
FHD0402UC5N6□ST		C, S, D, J, K	5.6	250	20	250	0.083	500	4800	760
FHD0402UC6N2□ST		C, S, D, J, K	6.2	250	23	250	0.083	500	4800	760
FHD0402UC6N8□ST		G, H, J, K	6.8	250	23	250	0.260	500	4800	680
FHD0402UC7N5□ST		G, H, J, K	7.5	250	23	250	0.100	500	4800	680
FHD0402UC8N2□ST		G, H, J, K	8.2	250	25	250	0.100	500	4400	680
FHD0402UC8N7□ST		G, H, J, K	8.7	250	25	250	0.200	500	4100	480
FHD0402UC9N0□ST		G, H, J, K	9.0	250	25	250	0.100	500	4160	680
FHD0402UC9N5□ST		G, H, J, K	9.5	250	25	250	0.200	500	4000	480
FHD0402UC010□ST		G, H, J, K	10	250	25	250	0.20	500	3900	480
FHD0402UC011□ST		G, H, J, K	11	250	25	250	0.120	500	3680	640



型号规格 Part NO.	客户料号 Customer P/N	精度级别 accuracy grade	标称感量 Inductance (nH)	感量测试频率 Ls Test frequency (MHz)	Q 值 (Min)	Q 值测试频率 Test frequency (MHz)	直流电阻 Rdc (Ω) max	测试电压 Test voltage (mV)	自谐振频率 SRF (MHz)min	额定电流 Idc (mA)max
FHD0402UC012□ST		J, K	12	250	25	250	0.120	500	3600	640
FHD0402UC013□ST		G, H, J, K	13	250	25	250	0.210	500	3450	440
FHD0402UC015□ST		G, H, J, K	15	250	25	250	0.300	500	3280	560
FHD0402UC016□ST		G, H, J, K	16	250	25	250	0.220	500	3100	560
FHD0402UC018□ST		G, H, J, K	18	250	25	250	0.230	500	3100	420
FHD0402UC019□ST		G, H, J, K	19	250	25	250	0.200	500	3040	480
FHD0402UC020□ST		G, H, J, K	20	250	25	250	0.250	500	3000	420
FHD0402UC022□ST		G, H, J, K	22	250	25	250	0.300	500	2800	400
FHD0402UC023□ST		G, H, J, K	23	250	22	250	0.380	500	2720	310
FHD0402UC024□ST		G, H, J, K	24	250	25	250	0.300	500	2700	400
FHD0402UC027□ST		G, H, J, K	27	250	24	250	0.520	500	2480	280
FHD0402UC030□ST		G, H, J, K	30	250	25	250	0.500	500	2350	400
FHD0402UC033□ST		G, H, J, K	33	250	24	250	0.650	500	2350	350
FHD0402UC036□ST		G, H, J, K	36	250	25	250	0.600	500	2320	250
FHD0402UC039□ST		G, H, J, K	39	250	25	250	0.750	500	2100	200
FHD0402UC040□ST		G, H, J, K	40	250	25	250	0.600	500	2240	220
FHD0402UC043□ST		J, K	43	250	25	250	0.810	500	2030	100
FHD0402UC047□ST		G, H, J, K	47	250	25	250	0.830	500	2100	150
FHD0402UC051□ST		J, K	51	250	25	250	0.820	500	1750	100
FHD0402UC056□ST		G, H, J, K	56	250	25	250	0.97	500	1760	100
FHD0402UC062□ST		G, H, J, K	62	250	25	250	1.120	500	1620	100
FHD0402UC068□ST		G, H, J, K	68	250	25	250	1.12	500	1620	100
FHD0402UC075□ST		G, H, J, K	75	250	25	250	1.630	500	1400	50
FHD0402UC082□ST		G, H, J, K	82	250	25	250	1.70	500	1260	50
FHD0402UCR10□ST		G, H, J, K	100	250	25	250	2.00	500	1160	30
FHD0402UCR12□ST		G, H, J, K	120	250	25	250	2.20	500	1100	30

□表示标称感量精度级别 represents the nominal sensitivity accuracy level: B±0.1nH; C±0.2nH; D±0.5nH; G---±2%; H---±3%; J---±5%; K---±10%。



4 可靠性试验项目 Reliability Testing Items

序号 No.	项目 Items	要求 Requirements	试验方法及备注 Test Methods and Remarks
1	试验用标准条件 Test Standard Conditions	<p>①、除非另有规定，所有试验和测量在下述条件进行。Unless otherwise specified, all tests and measurements shall be carried out in the following conditions.</p> <p>a) 温度 Temperature: 15°C~+35 °C; b) 相对湿度 Relative humidity: 25%~75%; c) 气压 pressure: 86 kPa~106 kPa。</p> <p>②、在上述条件下测定有异议发生场合，按下述条件进行。Under the above conditions, the conditions for the determination of dissension shall be conducted according to the following conditions.</p> <p>a) 温度 Temperature: 20°C±1°C; b) 相对湿度 Relative humidity: 63%~67%; c) 气压 pressure: 86 kPa~106 kPa。</p>	
2	工作温度范围 Operating Temperature Range	① FHD-UC series: -40°C~+125°C	/
3	可焊性 Solder ability	<p>①外观无可见损伤痕迹; No visible mechanical damage.</p> <p>②端电极表面焊锡覆盖率。 Electrode surface solder coverage. FHD-UC series: ≥90%;</p>	<p>在 245±5°C 熔融的焊锡 (96.5%Sn/3.0%Ag/0.5%Cu) 中浸置 5±1s。 Dip pads in flux and dip in solder pot(96.5Sn/3.0Ag/0.5Cu)at 245±5°C for 5±1s.</p>
4	耐焊接热 Resistance to Soldering	<p>①外观无可见损伤痕迹; No visible mechanical damage.</p> <p>②感量变化不超过±5%; Inductance shall not change more than ±5%;</p> <p>③FHD-UC series Q 值变化不超过±10%。 FHD-UC series Q shall not change more than±10%.</p>	<p>在 260±5°C 熔融的焊锡 (96.5%Sn/3.0%Ag/0.5%Cu) 中浸置 10±1s。 Dip pads in flux and dip in solder pot(96.5Sn/3.0Ag/0.5Cu)at 260±5°C for 10±1s.</p>

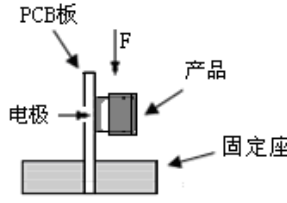

序号 No.	项目 Items	要求 Requirements	试验方法及备注 Test Methods and Remarks								
5	振动 Vibration	①外观无可见损伤痕迹; No visible mechanical damage. ②感量变化不超过±5%; Inductance shall not change more than ±5%; ③FHD-UC series Q 值变化不超过±10%. FHD-UC series Q shall not change more than±10%.	振幅 1.5mm, 频率 10~55Hz, 每个方向 (X、Y、Z) 保持 2 小时。Inductors shall be subjected to vibration of 1.5mm amplitude frequency 10~55Hz (10Hz to 55Hz to 10Hz in a period of 1 minute) for 2h in each of three(X、Y、Z) axes.								
6	端电极强度 Adhesion of electrode	①试验后端电极无脱落; The end electrode did not fall off after the test. ②外观无可见损伤痕迹。 No visible mechanical damage.	将产品焊在 PCB 板上, 按下图、表所示方向及要求施加作用力。Weld the product on the PCB board, and apply force as shown in the diagram, direction and requirement.  <table border="1" data-bbox="989 1120 1460 1310"> <thead> <tr> <th>尺寸规格 Size</th> <th>施加力要求</th> </tr> </thead> <tbody> <tr> <td>0402UC Series</td> <td>5 N</td> </tr> <tr> <td colspan="2">Keep time: (10±1)s</td> </tr> <tr> <td colspan="2">Speed: 1.0 mm/s.</td> </tr> </tbody> </table>	尺寸规格 Size	施加力要求	0402UC Series	5 N	Keep time: (10±1)s		Speed: 1.0 mm/s.	
尺寸规格 Size	施加力要求										
0402UC Series	5 N										
Keep time: (10±1)s											
Speed: 1.0 mm/s.											
7	耐低温 Low temperature resistance	①外观无可见损伤痕迹; No visible mechanical damage. ②感量变化不超过±5%; Inductance shall not change more than ±5%; ③FHD-UC series Q 值变化不超过±10%. FHD-UC series Q shall not change more than±10%.	①FHD-UC 系列产品放置于温度-40±2℃的环境中 +24 存放 1000—0 h FHD-UC series shall be subjected to-40±2℃ for +24 1000—0 h								



序号 No.	项目 Items	要求 Requirements	试验方法及备注 Test Methods and Remarks
8	耐高温 High temperature resistance	①外观无可见损伤痕迹; No visible mechanical damage. ②感量变化不超过±5%; Inductance shall not change more than ±5%; ③FHD-UC series Q 值变化不超过±10%。 FHD-UC series Q shall not change more than±10%.	①FHD-UC 系列产品放置于温度+125±5℃的环境 +24 中存放 1000—0 h FHD-UC series shall be subjected to +125±5℃ +24 for1000—0 h
9	温度冲击 Temperature Shock	①外观无可见损伤痕迹; No visible mechanical damage. ②感量变化不超过±5%; Inductance shall not change more than ±5%; ③FHD-UC series Q 值变化不超过±10%。 FHD-UC series Q shall not change more than±10%.	①FHD-UC 系列: +125℃ 30 分钟 ↔ -40℃ 30 分钟, 循环 100 次; FHD-UC series : +125℃ 30minutes ↔ -40℃ 30minutes 100 Cycles.
10	高温负载 High temperature load	①外观无可见损伤痕迹; No visible mechanical damage. ②感量变化不超过±5%; Inductance shall not change more than ±5%; ③FHD-UC series Q 值变化不超过±10%。 FHD-UC series Q shall not change more than±10%.	①FHD-UC 系列产品加额定电流在 125±2℃温度条 +24 件下存放 1000—0 h FHD-UC series shall be store at 125±2℃ for +24 1000—0 h with rated current applied.



序号 No.	项目 Items	要求 Requirements	试验方法及备注 Test Methods and Remarks
11	恒定湿热 Static Humidity	①外观无可见损伤痕迹; No visible mechanical damage. ②感量变化不超过±5%; Inductance shall not change more than ±5%; ③FHD-UC series Q 值变化不超过±10%。 FHD-UC series Q shall not change more than±10%.	将电感器放置在于湿度 90%~95%,温度 60±2℃的 +24 环境中存放 1000—0 h Inductors shall be subjected to 90%~95%RH. at +24 60±2℃ for 1000—0 h
12	抗弯强度 Bending strength	外观无可见损伤痕迹; No visible mechanical damage.	①将电感器安装于试验基板上; 在垂直方向施加力 (如下图所示)。Install the inductor on the test substrate; Apply force in the vertical direction (as shown below). ②该板应在 (1±0.5) mm/s 的弯曲速率向下弯曲 (2±0.2) mm, 保持时间 (20±1) s。The epoxy plate should bend down to (2±0.2) mm at the bending rate of (1±0.5) mm/s, Keep time (20±1) sec.
13	耐溶剂性 Solvent Resistance	①外观无可见损伤痕迹; No visible mechanical damage. ②感量变化不超过±5%; Inductance shall not change more than ±5%; ③FHD-UC series Q 值变化不超过±10%。 FHD-UC series Q shall not change more than±10%.	将元件浸泡在 23±5℃的异丙醇溶液中, 保持 5±0.5 分钟。 Soak in the element 23±5℃ in isopropyl alcohol solution, keep 5±0.5 min.

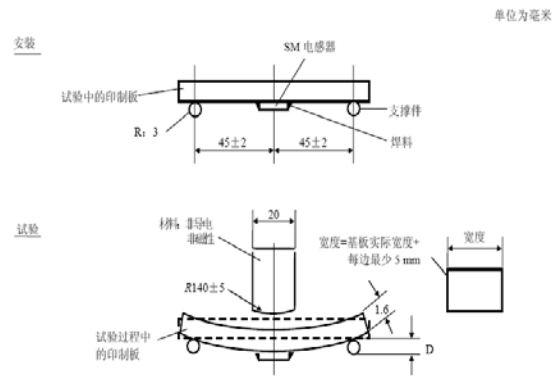

注: 以上要求测试电性能的项目, 在室温下放置至少 2 h 后在 48 h 内进行测试。

Note: When there are questions concerning, test within 48 h after placing at room temperature for at least 2 h.



5 产品包装 Packaging

1) 编带图 Taping drawings

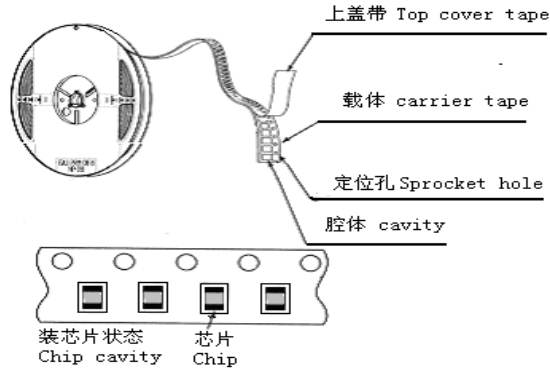

2) 卷盘尺寸 Reel dimensions (Unit: mm)

Part NO.	ΦA typ.	ΦB typ.	ΦC typ.	D typ.
0402	178	60	13	8.4

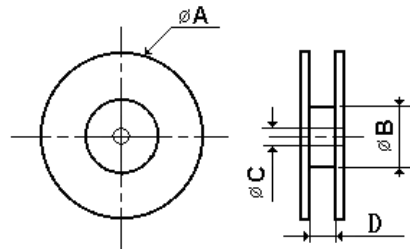

3) 导带及空格部分 Leader and blank portion

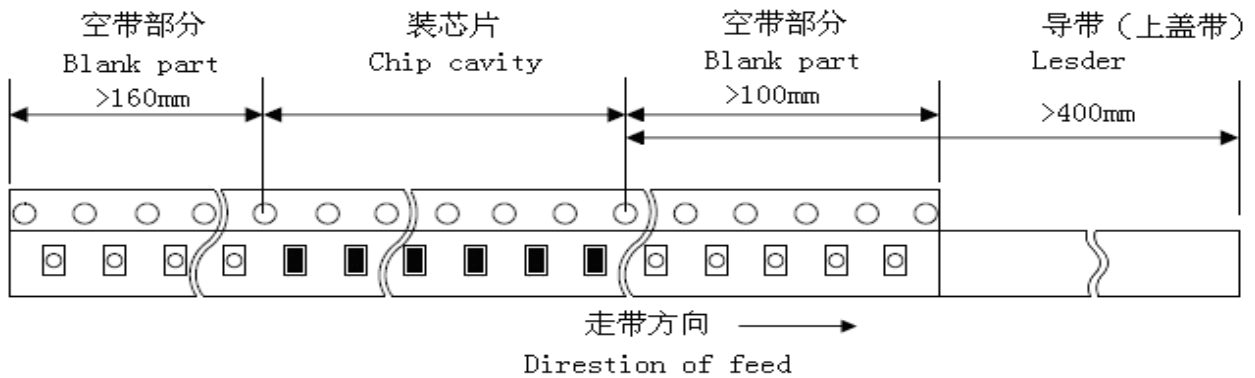

4) 编带尺寸 Taping dimensions (Unit: mm)

- 纸带 Paper tape

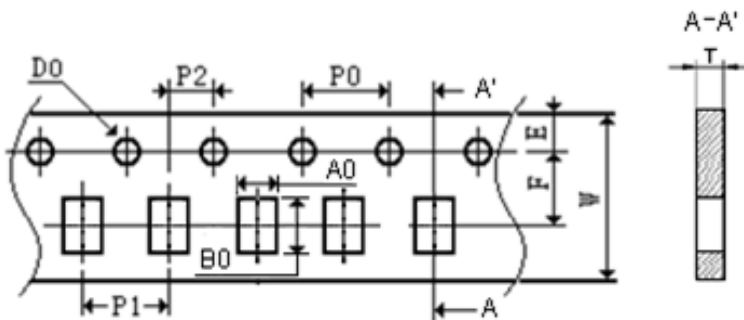



Part NO.	W	E	F	D0	P0	P1	P2	P0×10	A0	B0	T
0402	8.00	1.75	3.50	1.55	4	2	2	40	0.66	1.20	0.75

5) 剥离力检验 Peeling off force

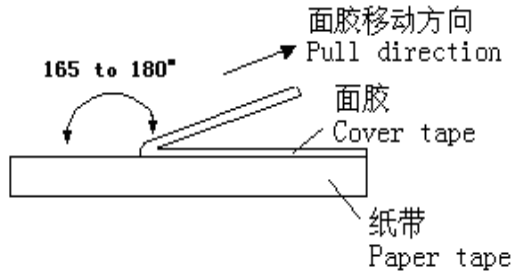

①盖带的剥离力要求 Peeling required

0402 系列 : 20 克~80 克 ;

0402 series : 20g~80g ;

②测试条件 Test condition

盖带剥离速度: 300mm/min±10%

Speed of peeling off : 300mm/min±10%

盖带剥离角度: 165° ~180°

Angle of peeling off: 165°~180°

6) 包装数量 (单位: 粒) Packaging number (Unit: Pcs)

类型 Size		0402
每卷数量 Per Reel		5000
每盒数量 Per Box	3 卷盒 3 Reel Per Box	15000
	5 卷盒 5 Reel Per Box	25000
每箱数量 Per Case	1.5 盒箱 1.5 Box Per Case	75000
	2 盒箱 2 Box Per Case	100000
	3 盒箱 3 Box Per Case	150000
	4 盒箱 4 Box Per Case	200000
	6 盒箱 6 Box Per Case	300000

7) 标签粘贴位置 Label stick station

卷盘标签 Reel label	纸盒标签 Carton label	纸盒标签 Carton label	外箱标签 Outer box label



6 推荐焊接条件 Recommend Soldering Conditions

1) 焊接条件 Soldering Conditions

本产品使用回流焊接法。

Applicable soldering process to the products is reflow soldering.

① 焊剂要求 Flux, Solder

- 使用松香基助焊剂，禁止使用卤化物含量超过 0.2(wt)%的强酸性助焊剂。
Don't use highly acidic flux with halide content exceeding 0.2(wt)%(chlorine conversion value).
- 使用无铅焊料 (96.5Sn /3.0Ag/0.5Cu)。
Using lead-free solder (96.5Sn /3.0Ag/0.5Cu).

② 焊接要求 Soldering conditions

- 预热时，产品表温与焊料温度的温差最大不允许超出 150℃，焊接完冷却时，产品表温与溶剂温度之间的温差最大不超过 100℃。预热不足有可能引发产品表面裂纹，从而导致产品品质下降。
Pre-heating should be in such a way that the temperature difference between solder and ferrite surface is limited to 150℃ max. Also cooling into solvent after soldering should be in such way that the temperature difference is limited to 100℃ max. Un-enough pre-heating may cause cracks on the ferrite, resulting in the deterioration of product quality.
- 产品要在以下画出的曲线允许的范围进行焊接。其它焊接条件可能引起产品电极的腐蚀。当焊接重复时，允许的时间为第一次做的累计时间。
Products should be soldered within the following allowable range indicated by the slanted line. The excessive soldering conditions may cause the corrosion of the electrode. When soldering is repeated, allowable time is the accumulated time.

2) 回流焊曲线 Reflow soldering profile

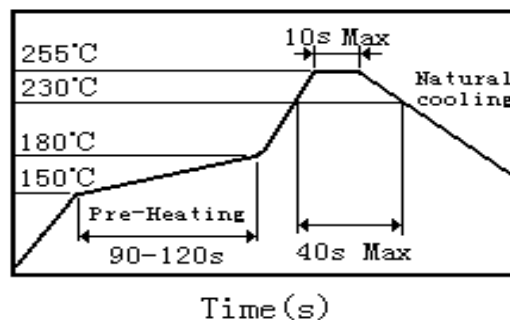

3) 手工焊接 Iron soldering

烙铁温度：350℃ (Max)

功率：最大为 30W

烙铁停留时间：<5S (注意不要将烙铁碰到产品线圈及包封层)。

Perform soldering at 350℃ on 30W max.

Soldering Time: < 5S (Take care not to apply the tip of the soldering iron to the terminal electrodes)。

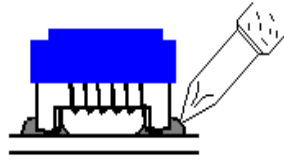

7 清洗 Cleaning

1) 清洗条件 Cleaning Conditions

- a. 清洗温度 : 60℃ (Max) Cleaning temperature : 60℃ max.
- b. 清洗时间 : 5 分钟 (Max) Cleaning time: 5 minutes Max.
- c. 超声波功率: 最大为 200W Ultrasonic output power: 200W max.

8 存储要求 Storage Requirements

1) 存储期限 Storage period

距电感公司出厂检验时间 1 年内, 产品可以使用检验时间可以通过包装外侧标记的检验号确认。若时间超过 1 年, 应检查焊接性能后方可使用。

Products which inspected inductor company over 1 year ago should be examined and used, which can be Confirmed with inspection No. marked on the container. Solder ability should be checked if this period is exceeded.

2) 存储条件 Storage conditions

- (1) 存放货物的库房应满足以下条件: 温度: -10 ~ +40℃, 相对湿度: 30 ~ 70%。
- (2) 禁止将产品保管在腐蚀性物质中, 如硫磺、氯气或酸, 否则将引起端头氧化, 导致降低焊接性。
- (3) 为了避免受潮气、灰尘等物质的影响, 产品应保管于货架上。
- (4) 产品保管在库房中, 应避免热冲击、振动以及直接光照等等。
- (5) 产品应密封包装。

(1) Products should be storage in the warehouse on the following conditions:

Temperature : -10~+40℃ Humidity: 30~70% relative humidity

- (2) Don't keep products in corrosive gases such as sulfur, chlorine gas or acid , or it may case oxidization of Electrodes resulting in poor solder ability.
- (3) Products should be stored on the palette for the prevention of the influence from humidity, dust and so on.
- (4) Products should be stored in the warehouse without heat shock, vibration, direct sunlight and so on.
- (5) Products should be stored under the airtight packaged condition.

9 ODS (消耗臭氧层物质) 的使用情况 Usage Of ODS

对于以下所列物质, 我公司在生产过程中绝不使用。

ODS: CCl₄ (四氯化碳)、HCFC 等。

For ODS listed below , we don't use in process.



ODS: CCl₄, HCFC, etc.

10 注意事项 Notes

(1) RoHS 指令 Response to RoHS directive

本公司产品符合 RoHS 指令。

Our products are RoHS compliance.

(2) 本承认书保证我司产品作为一个单体时的质量情况，当我司产品被安装到贵司产品上时请保证贵司的产品已根据贵司的规范进行了有效评价和确认。

This product specification guarantees the quality of our product as a single unit, Please make sure that your product has been evaluated and confirmed against your specifications when our product is mounted to your product.

(3) 如果贵司对我司产品的试用已超过了本测试规范所界定的产品功能，对于此所引发的失效我司将不予保证。

We can't warrant against failure caused by any use of our product that deviates from the intended use as described in this product specification.

(4) 为防止断线，请不要使用锋利的物体接触线圈，如镊子。

Do not touch wire with sharp objects such as tweezers to prevent wire breakage.



承 认 书

APPROVAL SHEET

客户名称:

Customer

产品名称:

绕线型片式电感器

Part Name

Wire Wound Chip inductor

产品规格:

FHD0603IF Series

Specification

版本号:

22.01

Version No.

日期:

2022-3-28

DATE

制造 Manufacturer			客户 Customer		
拟制 Draft by	审核 Checked by	确认 Approve by	检验 Check by	审核 Checked by	批准 Approval by
林晓华	徐雪枫	区军沛			



序号 No	目 录 TABLE OF CONTENTS
1	外形尺寸与内部结构 Dimension & Inner-configuration
2	产品品名构成 Product Spec. Model
3	电性能参数表 Electrical Characteristics List
4	可靠性试验项目 Reliability Testing Items
5	产品包装 Packaging
6	推荐焊接条件 Recommend Soldering Conditions
7	清洗 Cleaning
8	存储要求 Storage Requirements
9	ODS (消耗臭氧层物质) 的使用情况 Usage Of ODS
10	注意事项 Notes



1 外形尺寸与内部结构 Dimension & Inner-configuration :

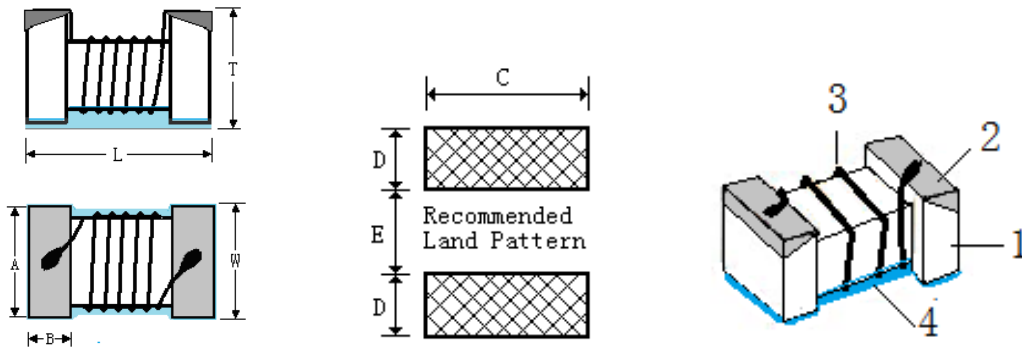

序号 No.	部位 Component	材料 Material								
1	磁芯 Core	铁氧体芯电感 Ferrite Core : 镍锌铁氧体 Ni-Zn ferrite								
2	电极 Electrode	<table border="1"> <thead> <tr> <th>分类 Type</th> <th>底层 Layout 0</th> <th>中层 Layout 1</th> <th>表层 Layout 2</th> </tr> </thead> <tbody> <tr> <td>铁氧体芯电感 Ferrite core</td> <td>银 Ag</td> <td>镍 Ni</td> <td>锡 Sn</td> </tr> </tbody> </table>	分类 Type	底层 Layout 0	中层 Layout 1	表层 Layout 2	铁氧体芯电感 Ferrite core	银 Ag	镍 Ni	锡 Sn
		分类 Type	底层 Layout 0	中层 Layout 1	表层 Layout 2					
铁氧体芯电感 Ferrite core	银 Ag	镍 Ni	锡 Sn							
3	漆包线 wire	铜 Cu								
4	封装层 encapsulation layer	树脂 UV Adhesive								

单位 Unit : mm (inch)

型号 Size	L (Max)	W (Max)	T (Max)	A	B	C	D	E
FHD0603IF	1.80(0.071)	1.20(0.047)	1.00(0.039)	0.90(0.035)	0.35(0.014)	1.02(0.040)	0.64(0.025)	0.70(0.028)

2 产品品名构成 Product Spec. Model

FHD 0603 IF 2R2 J S T
① ② ③ ④ ⑤ ⑥ ⑦

① 绕线型片式电感器系列 Wire Wound Inductor Series;

② 外形尺寸 Dimensions: 0603;

③ 芯片类型 Material: IF---铁氧体芯 Ferrite core;

④ 标称电感量 Inductance: 2R2=2.2μH;

⑤ 标称电感值偏差 Tolerance: J---±5%;

⑥ 电极表面镀层材料 Terminal: S--锡端头 Tin;

⑦ 包装类型 Packaging type: T---卷带盘装。



3 电性能参数表 Electrical Characteristics List

型号规格 Part NO.	客户料号 Customer P/N	误差范围 Tolerance (%)	标称感量 Inductance (μH)	感量测试频率 Ls Test frequency (MHz)	Q 值 (Min)	Q 值测试频率 Test frequency (MHz)	直流电阻 Rdc (Ω) max	测试电压 Test voltage (mV)	自谐振频率 SRF (MHz) _{min}	额定电流 Idc (mA) _{max}
FHD0603IF2R2JST		± 5	2.2	7.9	12	7.9	2.3	500	180	280
FHD0603IF4R7JST		± 5	4.7	7.9	12	7.9	4.0	500	80	200
FHD0603IF6R8JST		± 5	6.8	7.9	10	7.9	3.9	500	28	200
FHD0603IF100JST		± 5	10	2.5	10	2.5	4.8	500	25	180
FHD0603IF150JST		± 5	15	2.5	9	2.5	8.5	500	18	150
FHD0603IF220JST		± 5	22	2.5	9	2.5	12.0	500	10	100



4 可靠性试验项目 Reliability Testing Items

序号 No.	项目 Items	要求 Requirements	试验方法及备注 Test Methods and Remarks
1	试验用标准条件 Test Standard Conditions	<p>①、除非另有规定，所有试验和测量在下述条件进行。Unless otherwise specified, all tests and measurements shall be carried out in the following conditions.</p> <p>a) 温度 Temperature: 15℃~+35℃;</p> <p>b) 相对湿度 Relative humidity: 25%~75%;</p> <p>c) 气压 pressure: 86 kPa~106 kPa.</p> <p>②、在上述条件下测定有异议发生场合，按下述条件进行。Under the above conditions, the conditions for the determination of dissension shall be conducted according to the following conditions.</p> <p>a) 温度 Temperature: 20℃±1℃;</p> <p>b) 相对湿度 Relative humidity: 63%~67%;</p> <p>c) 气压 pressure: 86 kPa~106 kPa.</p>	
2	工作温度范围 Operating Temperature Range	FHD-IF series: -40~+85℃	/
3	可焊性 Solder ability	<p>①外观无可见损伤痕迹; No visible mechanical damage.</p> <p>②端电极表面焊锡覆盖率。 Electrode surface solder coverage. FHW-IF series: ≥80%。</p>	<p>在 245±5℃ 熔融的焊锡 (96.5%Sn/3.0%Ag/0.5%Cu) 中浸置 5±1s。</p> <p>Dip pads in flux and dip in solder pot(96.5Sn/3.0Ag/0.5Cu)at 245±5℃ for 5±1s.</p>
4	耐焊接热 Resistance to Soldering	<p>①外观无可见损伤痕迹; No visible mechanical damage.</p> <p>②感量变化不超过±5%; Inductance shall not change more than ±5%;</p> <p>③Q 值变化不超过±10%。 Q shall not change more than±10%.</p>	<p>在 260±5℃ 熔融的焊锡 (96.5%Sn/3.0%Ag/0.5%Cu) 中浸置 10±1s。</p> <p>Dip pads in flux and dip in solder pot(96.5Sn/3.0Ag/0.5Cu)at 260±5℃ for 10±1s.</p>
5	振动 Vibration	<p>①外观无可见损伤痕迹; No visible mechanical damage.</p> <p>②感量变化不超过±5%; Inductance shall not change more than ±5%;</p> <p>③Q 值变化不超过±10%。 Q shall not change more than±10%.</p>	<p>振幅 1.5mm, 频率 10~55Hz, 每个方向 (X、Y、Z) 保持 2 小时。Inductors shall be subjected to vibration of 1.5mm amplitude frequency 10~55Hz (10Hz to 55Hz to 10Hz in a period of 1 minute) for 2h in each of three(X、Y、Z) axes.</p>

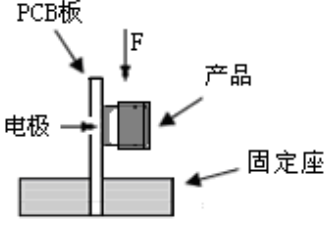

序号 No.	项目 Items	要求 Requirements	试验方法及备注 Test Methods and Remarks								
6	端电极强度 Adhesion of electrode	①试验后端电极无脱落; The end electrode did not fall off after the test. ②外观无可见损伤痕迹。 No visible mechanical damage.	将产品焊在 PCB 板上, 按下图、表所示方向及要求施加作用力。Weld the product on the PCB board, and apply force as shown in the diagram, direction and requirement.  <table border="1" data-bbox="997 806 1452 1019"> <tr> <td>尺寸规格 Size</td> <td>施加力要求</td> </tr> <tr> <td>0603IF Series</td> <td>7 N</td> </tr> <tr> <td colspan="2">Keep time: (10±1)s</td> </tr> <tr> <td colspan="2">Speed: 1.0 mm/s.</td> </tr> </table>	尺寸规格 Size	施加力要求	0603IF Series	7 N	Keep time: (10±1)s		Speed: 1.0 mm/s.	
尺寸规格 Size	施加力要求										
0603IF Series	7 N										
Keep time: (10±1)s											
Speed: 1.0 mm/s.											
7	耐低温 Low temperature resistance	①外观无可见损伤痕迹; No visible mechanical damage. ②感量变化不超过±5%; Inductance shall not change more than ±5%; ③Q 值变化不超过±10%。 Q shall not change more than±10%.	FHD-IF 系列产品放置于温度-40±2℃的环境中存放 1000 ⁺²⁴ ₋₀ h FHD-IF series shall be subjected to -40±2℃ for 1000 ⁺²⁴ ₋₀ h								
8	耐高温 High temperature resistance	①外观无可见损伤痕迹; No visible mechanical damage. ②感量变化不超过±5%; Inductance shall not change more than ±5%; ③Q 值变化不超过±10%。 Q shall not change more than±10%.	FHD-IF 系列产品放置于温度+85±5℃的环境中存放 1000 ⁺²⁴ ₋₀ h FHD-IF series shall be subjected to +85±5℃ for 1000 ⁺²⁴ ₋₀ h								
9	温度冲击 Temperature Shock	①外观无可见损伤痕迹; No visible mechanical damage. ②感量变化不超过±5%; Inductance shall not change more than ±5%; ③Q 值变化不超过±10%。 Q shall not change more than±10%.	FHD-IF 系列: +85℃ 30 分钟 ↔ -40℃ 30 分钟, 循环 100 次; FHD-IF series: +85℃ 30minutes ↔ -40℃ 30minutes 100 Cycles.								



序号 No.	项目 Items	要求 Requirements	试验方法及备注 Test Methods and Remarks
10	高温负载 High temperature load	①外观无可见损伤痕迹; No visible mechanical damage. ②感量变化不超过±5%; Inductance shall not change more than ±5%; ③Q 值变化不超过±10%. Q shall not change more than±10%.	FHD-IF 系列产品加额定电流在 85±2℃温度条件 +24 下存放 1000-0 h FHD-IF series shall be store at 85±2℃ for +24 1000-0 h with rated current applied.
11	恒定湿热 Static Humidity	①外观无可见损伤痕迹; No visible mechanical damage. ②感量变化不超过±5%; Inductance shall not change more than ±5%; ③Q 值变化不超过±10%. Q shall not change more than±10%.	将电感器放置在于湿度 90%~95%,温度 60±2℃ +24 的环境中存放 1000-0 h Inductors shall be subjected to 90%~95%RH. +24 at 60±2℃ for 1000-0 h
12	抗弯强度 Bending strength	外观无可见损伤痕迹; No visible mechanical damage.	①将电感器安装于试验基板上; 在垂直方向施加力(如下图所示)。Install the inductor on the test substrate; Apply force in the vertical direction (as shown below). ②该板应在 (1±0.5) mm/s 的弯曲速率向下弯曲 (2±0.2) mm, 保持时间 (20±1) s。The epoxy plate should bend down to (2±0.2) mm at the bending rate of (1±0.5) mm/s, Keep time (20±1) sec. 单位为毫米 安装 试验 试验过程中的印制板



序号 No.	项目 Items	要求 Requirements	试验方法及备注 Test Methods and Remarks
13	耐溶剂性 Solvent Resistance	①外观无可见损伤痕迹; No visible mechanical damage. ②感量变化不超过±5%; Inductance shall not change more than ±5%; ③Q 值变化不超过±10%. Q shall not change more than±10%.	将元件浸泡在 23±5℃ 的异丙醇溶液中, 保持 5±0.5 分钟。 Soak in the element 23±5℃ in isopropyl alcohol solution, keep 5±0.5 min.
注: 以上要求测试电性能的项目, 在室温下放置至少 2 h 后在 48 h 内进行测试。 Note: When there are questions concerning, test within 48 h after placing at room temperature for at least 2 h.			

5 产品包装 Packaging

1) 编带图 Taping drawings

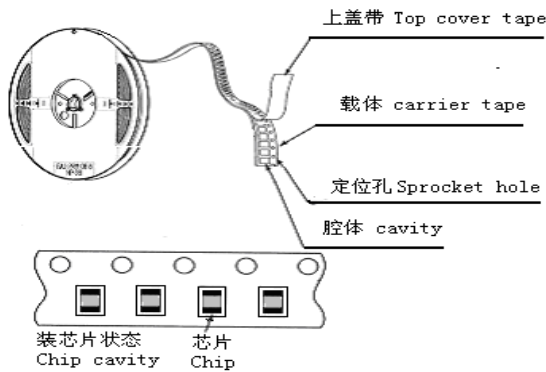

2) 卷盘尺寸 Reel dimensions (Unit: mm)

Part NO.	ΦA typ.	ΦB typ.	ΦC typ.	D typ.
0603	178	60	13	8.4

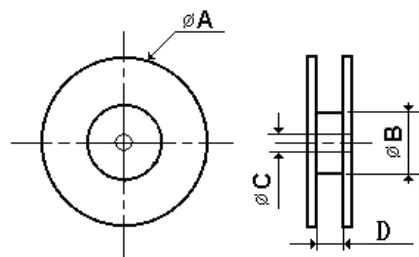

3) 导带及空格部分 Leader and blank portion

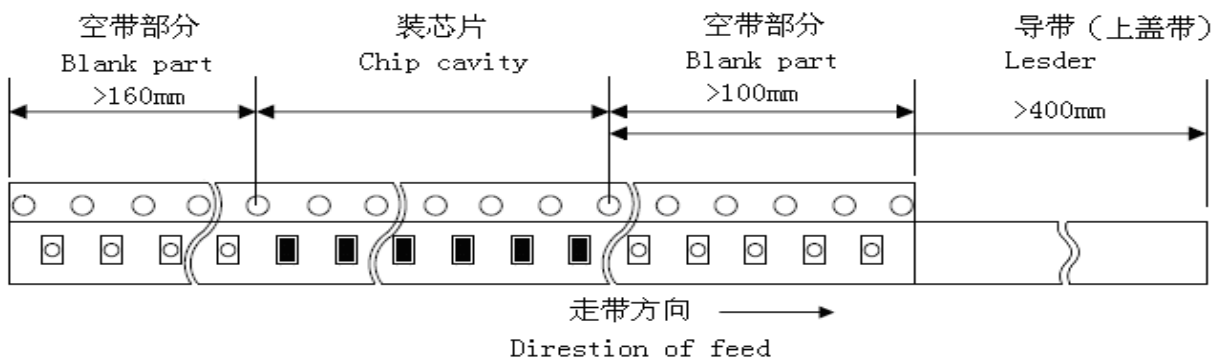



4) 编带尺寸 Taping dimensions (Unit: mm)

- 纸带 Paper tape

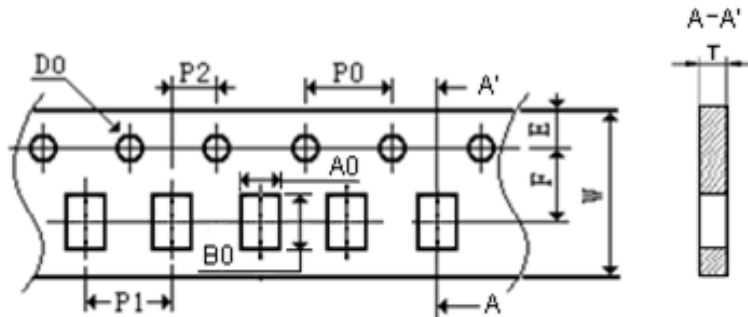

Part NO.	W	E	F	D0	P0	P1	P2	P0×10	A0	B0	T
0603	8.00	1.75	3.50	1.55	4	4	2	40	1.20	1.90	1.05

5) 剥离力检验 Peeling off force

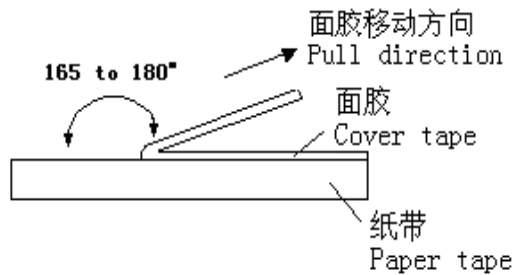

① 盖带的剥离力要求 Peeling required

0603 series : 20g~80g

② 测试条件 Test condition

盖带剥离速度: 300mm/min±10%

Speed of peeling off : 300mm/min±10%

盖带剥离角度: 165° ~180°

Angle of peeling off: 165°~180°

6) 包装数量 (单位: 粒) Packaging number (Unit: Pcs)

类型 Size		0603
每卷数量 Per Reel		4000
每盒数量 Per Box	3 卷盒 3 Reel Per Box	12000
	5 卷盒 5 Reel Per Box	20000
每箱数量 Per Case	1.5 盒箱 1.5 Box Per Case	60000
	2 盒箱 2 Box Per Case	80000
	3 盒箱 3 Box Per Case	120000



	4 盒箱 4 Box Per Case	160000
	6 盒箱 6 Box Per Case	240000

7) 标签粘贴位置 Label stick station

卷盘标签 Reel label	纸盒标签 Carton label	纸盒标签 Carton label	外箱标签 Outer box label
			

6 推荐焊接条件 Recommend Soldering Conditions

1) 焊接条件 Soldering Conditions

本产品使用回流焊接法。

Reflow soldering is applied to this product.

① 焊剂要求 Flux, Solder

- 使用松香基助焊剂，禁止使用卤化物含量超过 0.2(wt)%的强酸性助焊剂。
Don't use highly acidic flux with halide content exceeding 0.2(wt)%(chlorine conversion value).
- 使用无铅焊料 (96.5Sn /3.0Ag/0.5Cu)。
Using lead-free solder (96.5Sn /3.0Ag/0.5Cu)。

② 焊接要求 Soldering conditions

- 预热时，产品表温与焊料温度的温差最大不允许超出 150℃，焊接完冷却时，产品表温与溶剂温度之间的温差最大不超过 100℃。预热不足有可能引发产品表面裂纹，从而导致产品品质下降。
Pre-heating should be in such a way that the temperature difference between solder and ferrite surface is limited to 150℃ max. Also cooling into solvent after soldering should be in such way that the temperature difference is limited to 100℃ max. Un-enough pre-heating may cause cracks on the ferrite, resulting in the deterioration of product quality.
- 产品要在以下画出的曲线允许的范围进行焊接。其它焊接条件可能引起产品电极的腐蚀。当焊接重复时，允许的时间为第一次做的累计时间。
Products should be soldered within the following allowable range indicated by the slanted line. The excessive soldering conditions may cause the corrosion of the electrode. When soldering is repeated, allowable time is the accumulated time.

2) 回流焊曲线 Reflow soldering profile

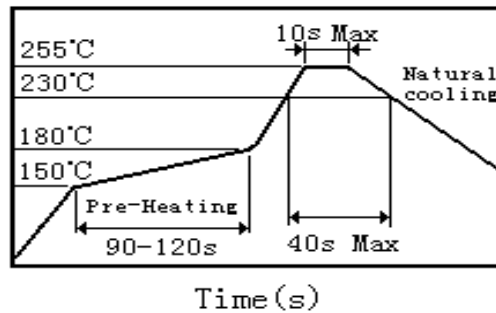

3) 手工焊接 Iron soldering

烙铁温度：350℃ (Max)

功率：最大为 30W

烙铁停留时间：<5S (注意不要将烙铁碰到产品线圈及包封层)。

Perform soldering at 350℃ on 30W max.

Soldering Time: < 5S (Take care not to apply the tip of the soldering iron to the terminal electrodes)。

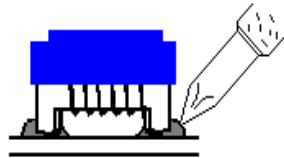

7 清洗 Cleaning

1) 清洗条件 Cleaning Conditions

a. 清洗温度：60℃ (Max) Cleaning temperature : 60℃ max.

b. 清洗时间：5 分钟 (Max) Cleaning time: 5 minutes Max.

c. 超声波功率：最大为 200W Ultrasonic output power: 200W max.

8 存储要求 Storage Requirements

1) 存储期限 Storage period

距电感公司出厂检验时间 1 年内，产品可以使用检验时间可以通过包装外侧标记的检验号确认。若时间超过 1 年，应检查焊接性能后方可使用。

Products which inspected inductor company over 1 year ago should be examined and used, which can be Confirmed with inspection No. marked on the container. Solder ability should be checked if this period is exceeded.

2) 存储条件 Storage conditions

(1) 存放货物的库房应满足以下条件：温度：-10 ~ +40℃，相对湿度：30 ~ 70%。

(2) 禁止将产品保管在腐蚀性物质中，如硫磺、氯气或酸，否则将引起端头氧化，导致降低焊接性。

(3) 为了避免受潮气、灰尘等物质的影响，产品应保管于货架上。

(4) 产品保管在库房中，应避免热冲击、振动以及直接光照等等。

(5) 产品应密封包装。

(1) Products should be storage in the warehouse on the following conditions:

Temperature : -10~+40℃ Humidity: 30~70% relative humidity

(2) Don't keep products in corrosive gases such as sulfur, chlorine gas or acid , or it may case



oxidization of Electrodes resulting in poor solder ability.

(3) Products should be stored on the palette for the prevention of the influence from humidity, dust and so on.

(4) Products should be stored in the warehouse without heat shock, vibration, direct sunlight and so on.

(5) Products should be stored under the airtight packaged condition.

9 ODS（消耗臭氧层物质）的使用情况 Usage Of ODS

对于以下所列物质，我公司在生产过程中绝不使用。

ODS: CCl₄（四氯化碳）、HCFC 等。

For ODS listed below , we don't use in process.

ODS: CCl₄, HCFC, etc.

10 注意事项 Notes

(1) RoHS 指令 Response to RoHS directive

本公司产品符合 RoHS 指令。

Our products are RoHS compliance.

(2) 本承认书保证我司产品作为一个单体时的质量情况，当我司产品被安装到贵公司产品上时请保证贵司的产品已根据贵司的规范进行了有效评价和确认。

This product specification guarantees the quality of our product as a single unit, Please make sure that your product has been evaluated and confirmed against your specifications when our product is mounted to your product.

(3) 如果贵司对我司产品的试用已超过了本测试规范所界定的产品功能，对于此所引发的失效我司将不予保证。

We can't warrant against failure caused by any use of our product that deviates from the intended use as described in this product specification.

(4) 为防止断线，请不要使用锋利的物体接触线圈，如镊子。

Do not touch wire with sharp objects such as tweezers to prevent wire breakage.



承 认 书

APPROVAL SHEET

客户名称:

Customer

/

产品名称:

绕线型片式电感器

Part Name

Wire Wound Chip inductor

产品规格:

FHD0603PF Series

Specification

版本号:

22.01

Version No.

日期:

2022-3-28

DATE

制造 Manufacturer			客户 Customer		
拟制 Draft by	审核 Checked by	确认 Approve by	检验 Check by	审核 Checked by	批准 Approval by
林晓华	徐雪枫	区军沛			



序号 No	目 录 TABLE OF CONTENTS
1	外形尺寸与内部结构 Dimension & Inner-configuration
2	产品品名构成 Product Spec. Model
3	电性能参数表 Electrical Characteristics List
4	可靠性试验项目 Reliability Testing Items
5	产品包装 Packaging
6	推荐焊接条件 Recommend Soldering Conditions
7	清洗 Cleaning
8	存储要求 Storage Requirements
9	ODS (消耗臭氧层物质) 的使用情况 Usage Of ODS
10	注意事项 Notes



1 外形尺寸与内部结构 Dimension & Inner-configuration :

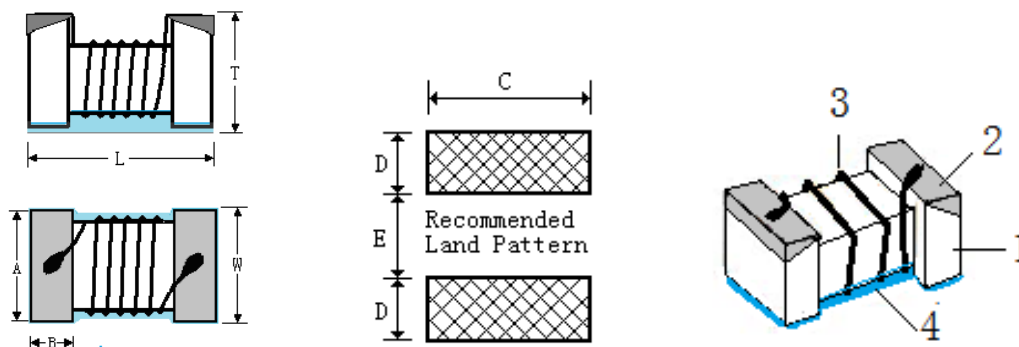

序号 No.	部位 Component	材料 Material								
1	磁芯 Core	铁氧体芯电感 Ferrite Core : 镍锌铁氧体 Ni-Zn ferrite								
2	电极 Electrode	<table border="1"> <thead> <tr> <th>分类 Type</th> <th>底层 Layout 0</th> <th>中层 Layout 1</th> <th>表层 Layout 2</th> </tr> </thead> <tbody> <tr> <td>铁氧体芯电感 Ferrite core</td> <td>银 Ag</td> <td>镍 Ni</td> <td>锡 Sn</td> </tr> </tbody> </table>	分类 Type	底层 Layout 0	中层 Layout 1	表层 Layout 2	铁氧体芯电感 Ferrite core	银 Ag	镍 Ni	锡 Sn
		分类 Type	底层 Layout 0	中层 Layout 1	表层 Layout 2					
铁氧体芯电感 Ferrite core	银 Ag	镍 Ni	锡 Sn							
3	漆包线 wire	铜 Cu								
4	封装层 encapsulation layer	树脂 UV Adhesive								

单位 Unit : mm (inch)

型号 Size	L (Max)	W (Max)	T (Max)	A	B	C	D	E
FHD0603PF	1.80(0.071)	1.20(0.047)	1.00(0.039)	0.90(0.035)	0.35(0.014)	1.02(0.040)	0.64(0.025)	0.70(0.028)

2 产品品名构成 Product Spec. Model

FHD 0603 PF 100 K S T
① ② ③ ④ ⑤ ⑥ ⑦

① 绕线型片式电感器系列 Wire Wound Inductor Series;

② 外形尺寸 Dimensions: 0603;

③ 芯片类型 Material: PF---铁氧体芯 Ferrite core;

④ 标称电感量 Inductance: 100=10 μ H;

⑤ 标称电感值偏差 Tolerance: K--- \pm 10%;

⑥ 电极表面镀层材料 Terminal: S--锡端头 Tin;

⑦ 包装类型 Packaging type: T---卷带盘装。



4 可靠性试验项目 Reliability Testing Items

序号 No.	项目 Items	要求 Requirements	试验方法及备注 Test Methods and Remarks
1	试验用标准条件 Test Standard Conditions	<p>①、除非另有规定，所有试验和测量在下述条件进行。Unless otherwise specified, all tests and measurements shall be carried out in the following conditions.</p> <p>a) 温度 Temperature: 15°C~+35 °C; b) 相对湿度 Relative humidity: 25%~75%; c) 气压 pressure: 86 kPa~106 kPa.</p> <p>②、在上述条件下测定有异议发生场合，按下述条件进行。Under the above conditions, the conditions for the determination of dissension shall be conducted according to the following conditions.</p> <p>a) 温度 Temperature: 20°C±1°C; b) 相对湿度 Relative humidity: 63%~67%; c) 气压 pressure: 86 kPa~106 kPa.</p>	
2	工作温度范围 Operating Temperature Range	FHD-PF series: -40~+85°C	/
3	可焊性 Solder ability	<p>①外观无可见损伤痕迹; No visible mechanical damage.</p> <p>②端电极表面焊锡覆盖率。 Electrode surface solder coverage. FHW-PF series: ≥80%.</p>	<p>在 245±5°C 熔融的焊锡 (96.5%Sn/ 3.0%Ag/0.5%Cu) 中浸置 5±1s。 Dip pads in flux and dip in solder pot(96.5Sn/3.0Ag/0.5Cu)at 245±5°C for 5±1s.</p>
4	耐焊接热 Resistance to Soldering	<p>①外观无可见损伤痕迹; No visible mechanical damage.</p> <p>②感量变化不超过±5%; Inductance shall not change more than ±5%.</p>	<p>在 260±5°C 熔融的焊锡 (96.5%Sn/ 3.0%Ag/0.5%Cu) 中浸置 10±1s。 Dip pads in flux and dip in solder pot(96.5Sn/3.0Ag/0.5Cu)at 260±5°C for 10±1s.</p>

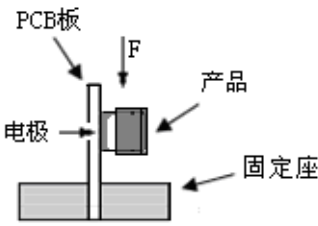

序号 No.	项目 Items	要求 Requirements	试验方法及备注 Test Methods and Remarks								
5	振动 Vibration	①外观无可见损伤痕迹; No visible mechanical damage. ②感量变化不超过±5%; Inductance shall not change more than ±5%.	振幅 1.5mm, 频率 10~55Hz, 每个方向(X、Y、Z)保持 2 小时。Inductors shall be subjected to vibration of 1.5mm amplitude frequency 10~55Hz (10Hz to 55Hz to 10Hz in a period of 1 minute) for 2h in each of three(X、Y、Z) axes.								
6	端电极强度 Adhesion of electrode	①试验后端电极无脱落; The end electrode did not fall off after the test. ②外观无可见损伤痕迹。 No visible mechanical damage.	将产品焊在 PCB 板上, 按下图、表所示方向及要求施加作用力。Weld the product on the PCB board, and apply force as shown in the diagram, direction and requirement.  <table border="1" data-bbox="997 1198 1452 1411"> <tr> <td>尺寸规格 Size</td> <td>施加力要求</td> </tr> <tr> <td>0603PF Series</td> <td>7 N</td> </tr> <tr> <td colspan="2">Keep time: (10±1)s</td> </tr> <tr> <td colspan="2">Speed: 1.0 mm/s.</td> </tr> </table>	尺寸规格 Size	施加力要求	0603PF Series	7 N	Keep time: (10±1)s		Speed: 1.0 mm/s.	
尺寸规格 Size	施加力要求										
0603PF Series	7 N										
Keep time: (10±1)s											
Speed: 1.0 mm/s.											
7	耐低温 Low temperature resistance	①外观无可见损伤痕迹; No visible mechanical damage. ②感量变化不超过±5%; Inductance shall not change more than ±5%.	FHD-PF 系列产品放置于温度-40±2℃的环境+24中存放 1000-0 h FHD-PF series shall be subjected to+24-40±2℃ for1000-0 h								



序号 No.	项目 Items	要求 Requirements	试验方法及备注 Test Methods and Remarks
8	耐高温 High temperature resistance	①外观无可见损伤痕迹; No visible mechanical damage. ②感量变化不超过±5%; Inductance shall not change more than ±5%.	FHD-PF 系列产品放置于温度+85±5℃的环境中 +24 存放 1000—0 h FHD-PF series shall be subjected to +85±5℃ +24 for 1000—0 h
9	温度冲击 Temperature Shock	①外观无可见损伤痕迹; No visible mechanical damage. ②感量变化不超过±5%; Inductance shall not change more than ±5%.	FHD-PF 系列:+85℃ 30分钟 ↔ -40℃ 30分, 钟循环 100 次; FHD-PF series : +85℃ 30minutes ↔ -40℃ 30minutes 100 Cycles.
10	高温负载 High temperature load	①外观无可见损伤痕迹; No visible mechanical damage. ②感量变化不超过±5%; Inductance shall not change more than ±5%.	FHD-PF 系列产品加额定电流在 85±2℃温度条件 +24 下存放 1000—0 h FHD-PF series shall be store at 85±2℃ for +24 1000—0 h with rated current applied.

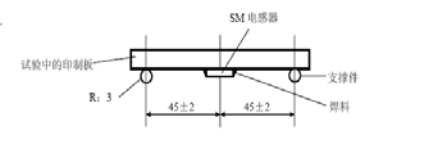
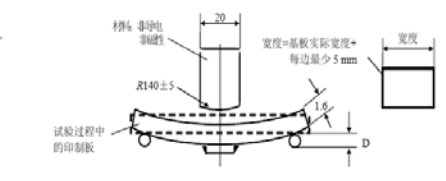

序号 No.	项目 Items	要求 Requirements	试验方法及备注 Test Methods and Remarks
11	恒定湿热 Static Humidity	①外观无可见损伤痕迹; No visible mechanical damage. ②感量变化不超过±5%; Inductance shall not change more than ±5%.	将电感器放置在于湿度 90%~95%,温度 $60 \pm 2^{\circ}\text{C}$ $+24$ 的环境中存放 1000 -0 h Inductors shall be subjected to 90%~95%RH. $+24$ at $60 \pm 2^{\circ}\text{C}$ for 1000 -0 h
12	抗弯强度 Bending strength	外观无可见损伤痕迹; No visible mechanical damage.	①将电感器安装于试验基板上; 在垂直方向施加力(如下图所示)。Install the inductor on the test substrate; Apply force in the vertical direction (as shown below). ②该板应在 (1 ± 0.5) mm/s 的弯曲速率向下弯曲 (2 ± 0.2) mm, 保持时间 (20 ± 1) 。The epoxy plate should bend down to (2 ± 0.2) mm at the bending rate of (1 ± 0.5) mm/s, Keep time (20 ± 1) sec. 单位为毫米 安装  试验 
13	耐溶剂性 Solvent Resistance	①外观无可见损伤痕迹; No visible mechanical damage. ②感量变化不超过±5%; Inductance shall not change more than ±5%.	将元件浸泡在 $23 \pm 5^{\circ}\text{C}$ 的异丙醇溶液中, 保持 5 ± 0.5 分钟。 Soak in the element $23 \pm 5^{\circ}\text{C}$ in isopropyl alcohol solution, keep 5 ± 0.5 min.

注: 以上要求测试电性能的项目, 在室温下放置至少 2 h 后在 48 h 内进行测试。

Note: When there are questions concerning, test within 48 h after placing at room temperature for at least 2 h.



5 产品包装 Packaging

1) 编带图 Taping drawings

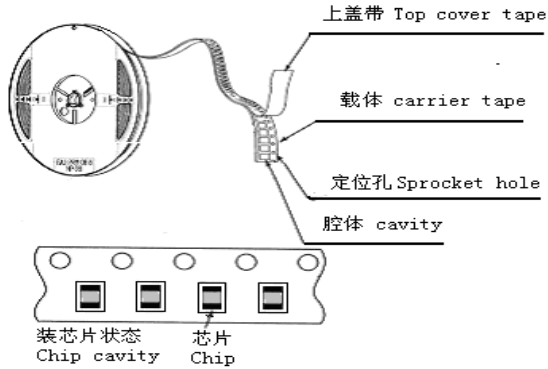

2) 卷盘尺寸 Reel dimensions (Unit: mm)

Part NO.	ΦA typ.	ΦB typ.	ΦC typ.	D typ.
0603	178	60	13	8.4

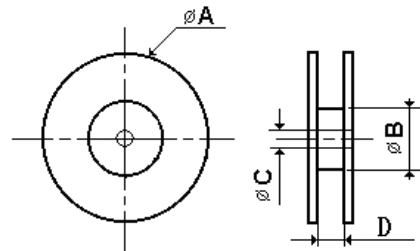

3) 导带及空格部分 Leader and blank portion

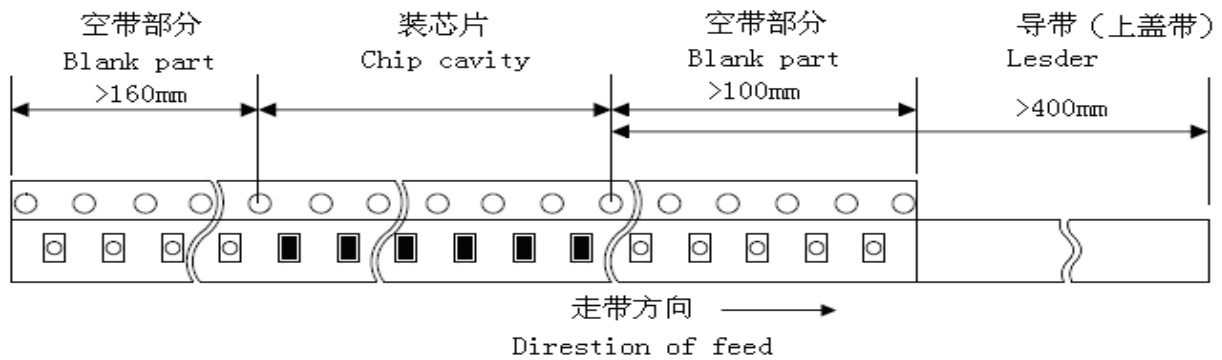

4) 编带尺寸 Taping dimensions (Unit: mm)

- 纸带 Paper tape

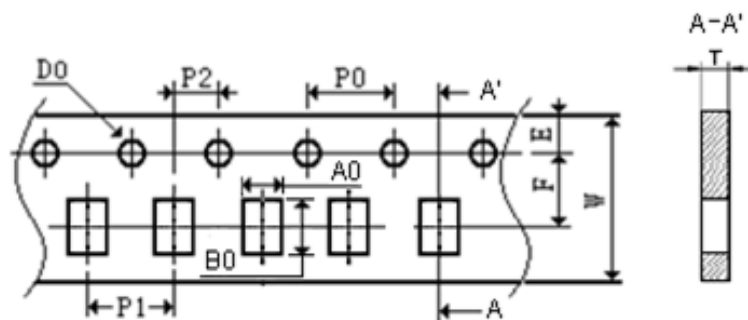



Part NO.	W	E	F	D0	P0	P1	P2	P0×10	A0	B0	T
0603	8.00	1.75	3.50	1.55	4	4	2	40	1.20	1.90	1.05

5) 剥离力检验 Peeling off force

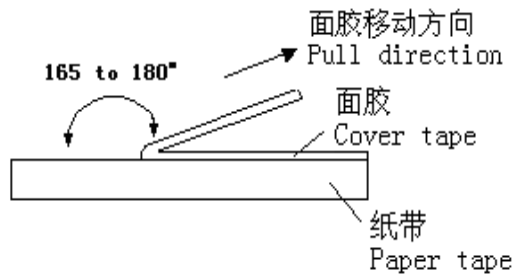

① 盖带的剥离力要求 Peeling required

0603 series : 20g~80g

② 测试条件 Test condition

盖带剥离速度: 300mm/min±10%

Speed of peeling off : 300mm/min±10%

盖带剥离角度: 165° ~180°

Angle of peeling off: 165°~180°

6) 包装数量 (单位: 粒) Packaging number (Unit: Pcs)

类型 Size		0603
每卷数量 Per Reel		4000
每盒数量 Per Box	3 卷盒 3 Reel Per Box	12000
	5 卷盒 5 Reel Per Box	20000
每箱数量 Per Case	1.5 盒箱 1.5 Box Per Case	60000
	2 盒箱 2 Box Per Case	80000
	3 盒箱 3 Box Per Case	120000
	4 盒箱 4 Box Per Case	160000
	6 盒箱 6 Box Per Case	240000

7) 标签粘贴位置 Label stick station

卷盘标签 Reel label	纸盒标签 Carton label	纸盒标签 Carton label	外箱标签 Outer box label



6 推荐焊接条件 Recommend Soldering Conditions

1) 焊接条件 Soldering Conditions

本产品使用回流焊接法。

Reflow soldering is applied to this product.

① 焊剂要求 Flux, Solder

- 使用松香基助焊剂，禁止使用卤化物含量超过 0.2(wt)% 的强酸性助焊剂。

Don't use highly acidic flux with halide content exceeding 0.2(wt)%(chlorine conversion value).

- 使用无铅焊料 (96.5Sn /3.0Ag/0.5Cu)。

Using lead-free solder (96.5Sn /3.0Ag/0.5Cu)。

② 焊接要求 Soldering conditions

- 预热时，产品表温与焊料温度的温差最大不允许超出 150℃，焊接完冷却时，产品表温与溶剂温度之间的温差最大不超过 100℃。预热不足有可能引发产品表面裂纹，从而导致产品品质下降。

Pre-heating should be in such a way that the temperature difference between solder and ferrite surface is limited to 150℃ max. Also cooling into solvent after soldering should be in such way that the temperature difference is limited to 100℃ max. Un-enough pre-heating may cause cracks on the ferrite, resulting in the deterioration of product quality.

- 产品要在以下画出的曲线允许的范围进行焊接。其它焊接条件可能引起产品电极的腐蚀。当焊接重复时，允许的时间为第一次做的累计时间。

Products should be soldered within the following allowable range indicated by the slanted line. The excessive soldering conditions may cause the corrosion of the electrode. When soldering is repeated, allowable time is the accumulated time.

2) 回流焊曲线 Reflow soldering profile

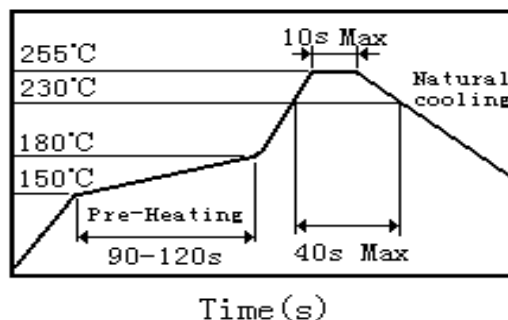

3) 手工焊接 Iron soldering

烙铁温度：350℃ (Max)

功率：最大为 30W

烙铁停留时间：<5S (注意不要将烙铁碰到产品线圈及包封层)。

Perform soldering at 350℃ on 30W max.

Soldering Time: < 5S (Take care not to apply the tip of the soldering iron to the terminal electrodes)。

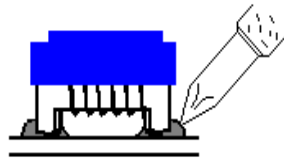

7 清洗 Cleaning

1) 清洗条件 Cleaning Conditions

- a. 清洗温度 : 60°C (Max) Cleaning temperature : 60°C max.
- b. 清洗时间 : 5 分钟 (Max) Cleaning time: 5 minutes Max.
- c. 超声波功率: 最大为 200W Ultrasonic output power: 200W max.

8 存储要求 Storage Requirements

1) 存储期限 Storage period

距电感公司出厂检验时间 1 年内, 产品可以使用检验时间可以通过包装外侧标记的检验号确认。若时间超过 1 年, 应检查焊接性能后方可使用。

Products which inspected inductor company over 1 year ago should be examined and used, which can be Confirmed with inspection No. marked on the container. Solder ability should be checked if this period is exceeded.

2) 存储条件 Storage conditions

- (1) 存放货物的库房应满足以下条件: 温度: -10 ~ +40°C, 相对湿度: 30 ~ 70%。
- (2) 禁止将产品保管在腐蚀性物质中, 如硫磺、氯气或酸, 否则将引起端头氧化, 导致降低焊接性。
- (3) 为了避免受潮气、灰尘等物质的影响, 产品应保管于货架上。
- (4) 产品保管在库房中, 应避免热冲击、振动以及直接光照等等。
- (5) 产品应密封包装。

(1) Products should be storage in the warehouse on the following conditions:

Temperature : -10~+40°C Humidity: 30~70% relative humidity

- (2) Don't keep products in corrosive gases such as sulfur, chlorine gas or acid , or it may case oxidization of Electrodes resulting in poor solder ability.
- (3) Products should be stored on the palette for the prevention of the influence from humidity, dust and so on.
- (4) Products should be stored in the warehouse without heat shock, vibration, direct sunlight and so on.
- (5) Products should be stored under the airtight packaged condition.

9 ODS (消耗臭氧层物质) 的使用情况 Usage Of ODS

对于以下所列物质, 我公司在生产过程中绝不使用。

ODS: CCl₄ (四氯化碳)、HCFC 等。

For ODS listed below , we don't use in process.

ODS: CCl₄, HCFC, etc.



10 注意事项 Notes

(1) RoHS 指令 Response to RoHS directive

本公司产品符合 RoHS 指令。

Our products are RoHS compliance.

(2) 本承认书保证我司产品作为一个单体时的质量情况，当我司产品被安装到贵司产品上时请保证贵司的产品已根据贵司的规范进行了有效评价和确认。

This product specification guarantees the quality of our product as a single unit, Please make sure that your product has been evaluated and confirmed against your specifications when our product is mounted to your product.

(3) 如果贵司对我司产品的试用已超过了本测试规范所界定的产品功能，对于此所引发的失效我司将不予保证。

We can't warrant against failure caused by any use of our product that deviates from the intended use as described in this product specification.

(4) 为防止断线，请不要使用锋利的物体接触线圈，如镊子。

Do not touch wire with sharp objects such as tweezers to prevent wire breakage.



承 认 书

APPROVAL SHEET

客户名称:

Customer

/

产品名称:

Part Name

绕线型片式电感器

Wire Wound Chip inductor

产品规格:

Specification

FHD0603UC Series

版本号:

Version No.

22.01

日期:

DATE

2022-3-15

制造 Manufacturer			客户 Customer		
拟制 Draft by	审核 Checked by	确认 Approve by	检验 Check by	审核 Checked by	批准 Approval by
林晓华	徐雪枫	区军沛			



序号 No	目 录 TABLE OF CONTENTS
1	外形尺寸与内部结构 Dimension & Inner-configuration
2	产品品名构成 Product Spec. Model
3	电性能参数表 Electrical Characteristics List
4	可靠性试验项目 Reliability Testing Items
5	产品包装 Packaging
6	推荐焊接条件 Recommend Soldering Conditions
7	清洗 Cleaning
8	存储要求 Storage Requirements
9	ODS (消耗臭氧层物质) 的使用情况 Usage Of ODS
10	注意事项 Notes



1 外形尺寸与内部结构 Dimension & Inner-configuration :

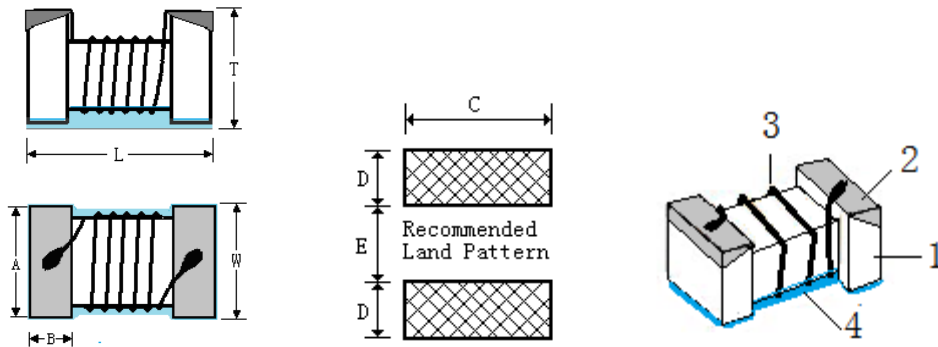

序号 No.	部位 Component	材料 Material								
1	瓷Core	陶瓷芯电感Ceramic Core : 陶瓷体Al ₂ O ₃								
2	电极Electrode	<table border="1"> <thead> <tr> <th>分类 Type</th> <th>底层 Layout 0</th> <th>中层 Layout 1</th> <th>表层 Layout 2</th> </tr> </thead> <tbody> <tr> <td>陶瓷芯电感 Ceramic core</td> <td>钨或钼锰或银/银钯 W or Mo-Mn or Ag/Ag-Pd</td> <td>镍 Ni</td> <td>锡 Sn</td> </tr> </tbody> </table>	分类 Type	底层 Layout 0	中层 Layout 1	表层 Layout 2	陶瓷芯电感 Ceramic core	钨或钼锰或银/银钯 W or Mo-Mn or Ag/Ag-Pd	镍 Ni	锡 Sn
分类 Type	底层 Layout 0	中层 Layout 1	表层 Layout 2							
陶瓷芯电感 Ceramic core	钨或钼锰或银/银钯 W or Mo-Mn or Ag/Ag-Pd	镍 Ni	锡 Sn							
3	漆包线wire	铜Cu								
4	封装层encapsulation layer	树脂UV Adhesive								

单位Unit : mm (inch)

型号 Size	L (Max)	W (Max)	T (Max)	A	B	C	D	E
1608(0603)	1.78(0.070)	1.10(0.043)	1.00(0.039)	0.90(0.035)	0.31(0.012)	1.02(0.040)	0.64(0.025)	0.64(0.025)

2 产品品名构成 Product Spec. Model

FHD 0603 UC R10 J S T

① ② ③ ④ ⑤ ⑥ ⑦

- ① 绕线型片式电感器系列 Wire Wound Inductor Series;
- ② 外形尺寸 Dimensions: 0402、0603;
- ③ 芯片类型 Material: UC---陶瓷芯 Ceramic core; IF---铁氧体芯 Ferrite core;
- ④ 标称电感量 Inductance: 1N0=1.0nH、010=10nH、R10=100nH、1R0=1.0μH、100=10μH
- ⑤ 标称电感值偏差 Tolerance: B±0.1nH; C±0.2nH; D±0.5nH; G---±2%; H---±3%; J---±5%; K---±10%; M---±20%;
- ⑥ 电极表面镀层材料 Terminal: S---锡端头 Tin;
- ⑦ 包装类型 Packaging type: T---卷带盘装 Tape& Reel.



3 电性能参数表 Electrical Characteristics List

型号规格 Part NO.	客户料号 Customer P/N	精度 级别 accuracy grade	标称 感量 Inductance (nH)	感量测试 频率 Ls Test frequency (MHz)	Q 值 (Min)	Q 值测试 频率 Test frequency (MHz)	直流 电阻 Rdc (Ω) max	测试 电压 Test voltage (mV)	自谐振 频率 SRF (MHz)min	额定电流 Idc (mA)max
FHD0603UC1N6□ST		C, S, D, K	1.6	250	18	250	0.04	500	12500	700
FHD0603UC1N7□ST		B, C, S, D, K	1.7	250	18	250	0.045	500	12500	700
FHD0603UC1N8□ST		C, S, D, K	1.8	250	16	250	0.045	500	12500	700
FHD0603UC2N0□ST		C, S, D, K	2.0	250	12	250	0.09	500	10000	700
FHD0603UC2N2□ST		C, S, D, K	2.2	250	12	250	0.09	500	10000	700
FHD0603UC3N3□ST		S, D, K	3.3	250	20	250	0.075	500	5900	700
FHD0603UC3N6□ST		B, C, S, D, K	3.6	250	22	250	0.075	500	5900	700
FHD0603UC3N9□ST		B, C, S, D, K	3.9	250	22	250	0.08	500	6900	700
FHD0603UC4N3□ST		B, C, S, D, K	4.3	250	22	250	0.075	500	5900	700
FHD0603UC4N7□ST		B, C, S, D, K	4.7	250	20	250	0.116	500	5800	700
FHD0603UC5N1□ST		B, C, S, D, K	5.1	250	20	250	0.120	500	5700	700
FHD0603UC6N0□ST		C, S, D, K	6.0	250	27	250	0.11	500	5700	700
FHD0603UC6N2□ST		C, S, D, K	6.2	250	27	250	0.11	500	5700	700
FHD0603UC6N8□ST		G, H, J, K	6.8	250	27	250	0.11	500	5800	700
FHD0603UC7N5□ST		G, H, J, K	7.5	250	28	250	0.11	500	4800	700
FHD0603UC8N2□ST		G, H, J, K	8.2	250	28	250	0.12	500	4700	700
FHD0603UC8N7□ST		G, H, J, K	8.7	250	28	250	0.12	500	4600	700
FHD0603UC9N1□ST		G, H, J, K	9.1	250	26	250	0.15	500	4500	700
FHD0603UC9N5□ST		G, H, J, K	9.5	250	26	250	0.15	500	5400	700
FHD0603UC010□ST		G, H, J, K	10	250	31	250	0.13	500	4800	700
FHD0603UC011□ST		G, H, J, K	11	250	33	250	0.13	500	4000	700
FHD0603UC012□ST		G, H, J, K	12	250	35	250	0.13	500	4000	700
FHD0603UC013□ST		G, H, J, K	13	250	30	250	0.14	500	4000	700
FHD0603UC014□ST		G, H, J, K	14	250	35	250	0.14	500	4000	700
FHD0603UC015□ST		G, H, J, K	15	250	30	250	0.15	500	4000	700



型号规格 Part NO.	客户料号 Customer P/N	精度 级别 accuracy grade	标称 感量 Inductance (nH)	感量测试 频率 Ls Test frequency (MHz)	Q 值 (Min)	Q 值测试 频率 Test frequency (MHz)	直流 电阻 Rdc (Ω) max	测试 电压 Test voltage (mV)	自谐振 频率 SRF (MHz)min	额定电流 Idc (mA)max
FHD0603UC016□ST		G, H, J, K	16	250	34	250	0.16	500	3300	700
FHD0603UC018□ST		G, H, J, K	18	250	35	250	0.17	500	3100	700
FHD0603UC020□ST		G, H, J, K	20	250	38	250	0.19	500	3000	700
FHD0603UC022□ST		G, H, J, K	22	250	38	250	0.19	500	3000	700
FHD0603UC024□ST		G, H, J, K	24	250	37	250	0.20	500	2650	700
FHD0603UC025□ST		G, H, J, K	25	250	38	250	0.21	500	2600	700
FHD0603UC027□ST		G, H, J, K	27	250	36	250	0.22	500	2800	600
FHD0603UC030□ST		G, H, J, K	30	250	37	250	0.22	500	2250	600
FHD0603UC033□ST		G, H, J, K	33	250	36	250	0.22	500	2300	600
FHD0603UC036□ST		G, H, J, K	36	250	36	250	0.25	500	2080	600
FHD0603UC039□ST		G, H, J, K	39	250	40	250	0.25	500	2200	600
FHD0603UC043□ST		G, H, J, K	43	250	36	250	0.28	500	2000	600
FHD0603UC047□ST		G, H, J, K	47	200	36	200	0.28	500	2000	600
FHD0603UC049□ST		G, H, J, K	49	200	36	200	0.28	500	2000	600
FHD0603UC051□ST		G, H, J, K	51	200	36	200	0	500	1900	600
FHD0603UC056□ST		G, H, J, K	56	200	38	200	0.28	500	1900	600
FHD0603UC068□ST		G, H, J, K	68	200	36	200	0.34	500	1700	600
FHD0603UC072□ST		G, H, J, K	72	150	34	150	0.53	500	1700	400
FHD0603UC075□ST		G, H, J, K	75	150	30	150	0.60	500	1400	400
FHD0603UC082□ST		G, H, J, K	82	150	34	150	0.55	500	1700	400
FHD0603UC091□ST		G, H, J, K	91	150	30	150	0.63	500	1400	400
FHD0603UCR10□ST		G, H, J, K	100	150	30	150	0.63	500	1400	400
FHD0603UCR11□ST		G, H, J, K	110	150	32	150	0.67	500	1350	300
FHD0603UCR12□ST		G, H, J, K	120	150	32	150	0.73	500	1300	300
FHD0603UCR15□ST		G, H, J, K	150	150	28	150	0.80	500	990	280
FHD0603UCR16□ST		G, H, J, K	160	100	25	100	1.25	500	990	250
FHD0603UCR18□ST		G, H, J, K	180	100	25	100	1.45	500	990	240



4 可靠性试验项目 Reliability Testing Items

序号 No.	项目 Items	要求 Requirements	试验方法及备注 Test Methods and Remarks
1	试验用标准条件 Test Standard Conditions	<p>①、除非另有规定，所有试验和测量在下述条件进行。Unless otherwise specified, all tests and measurements shall be carried out in the following conditions.</p> <p>a) 温度 Temperature: 15°C~+35 °C; b) 相对湿度 Relative humidity: 25%~75%; c) 气压 pressure: 86 kPa~106 kPa。</p> <p>②、在上述条件下测定有异议发生场合，按下述条件进行。Under the above conditions, the conditions for the determination of dissension shall be conducted according to the following conditions.</p> <p>a) 温度 Temperature: 20°C±1°C; b) 相对湿度 Relative humidity: 63%~67%; c) 气压 pressure: 86 kPa~106 kPa。</p>	
2	工作温度范围 Operating Temperature Range	① FHD-UC series: -40°C~+125°C	/
3	可焊性 Solder ability	<p>①外观无可见损伤痕迹; No visible mechanical damage.</p> <p>②端电极表面焊锡覆盖率。 Electrode surface solder coverage. FHD-UC series: ≥90%。</p>	<p>在 245±5°C 熔融的焊锡 (96.5%Sn/ 3.0%Ag/0.5%Cu) 中浸置 5±1s。 Dip pads in flux and dip in solder pot(96.5Sn/3.0Ag/0.5Cu)at 245±5°C for 5±1s.</p>
4	耐焊接热 Resistance to Soldering	<p>①外观无可见损伤痕迹; No visible mechanical damage.</p> <p>②感量变化不超过±5%; Inductance shall not change more than ±5%;</p> <p>③FHD-UC series Q 值变化不超过±10%。 FHD-UC series Q shall not change more than±10%.</p>	<p>在 260±5°C 熔融的焊锡 (96.5%Sn/ 3.0%Ag/0.5%Cu) 中浸置 10±1s。 Dip pads in flux and dip in solder pot(96.5Sn/3.0Ag/0.5Cu)at 260±5°C for 10±1s.</p>

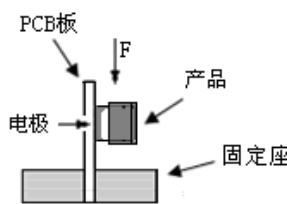

序号 No.	项目 Items	要求 Requirements	试验方法及备注 Test Methods and Remarks								
5	振动 Vibration	①外观无可见损伤痕迹; No visible mechanical damage. ②感量变化不超过±5%; Inductance shall not change more than ±5%; ③FHD-UC series Q 值变化不超过±10%. FHD-UC series Q shall not change more than±10%.	振幅 1.5mm, 频率 10~55Hz, 每个方向 (X、Y、Z) 保持 2 小时。Inductors shall be subjected to vibration of 1.5mm amplitude frequency 10~55Hz (10Hz to 55Hz to 10Hz in a period of 1 minute) for 2h in each of three(X、Y、Z) axes.								
6	端电极强度 Adhesion of electrode	①试验后端电极无脱落; The end electrode did not fall off after the test. ②外观无可见损伤痕迹。 No visible mechanical damage.	将产品焊在 PCB 板上, 按下图、表所示方向及要求施加作用力。Weld the product on the PCB board, and apply force as shown in the diagram, direction and requirement.  <table border="1" data-bbox="989 1153 1460 1344"> <thead> <tr> <th>尺寸规格 Size</th> <th>施加力要求</th> </tr> </thead> <tbody> <tr> <td>0603UC Series</td> <td>13 N</td> </tr> <tr> <td colspan="2">Keep time: (10±1)s</td> </tr> <tr> <td colspan="2">Speed: 1.0 mm/s.</td> </tr> </tbody> </table>	尺寸规格 Size	施加力要求	0603UC Series	13 N	Keep time: (10±1)s		Speed: 1.0 mm/s.	
尺寸规格 Size	施加力要求										
0603UC Series	13 N										
Keep time: (10±1)s											
Speed: 1.0 mm/s.											
7	耐低温 Low temperature resistance	①外观无可见损伤痕迹; No visible mechanical damage. ②感量变化不超过±5%; Inductance shall not change more than ±5%; ③FHD-UC series Q 值变化不超过±10%. FHD-UC series Q shall not change more than±10%.	①FHD-UC 系列产品放置于温度-40±2℃的环境中+24 存放 1000—0 h FHD-UC series shall be subjected to-40±2℃ for +24 1000—0 h								



序号 No.	项目 Items	要求 Requirements	试验方法及备注 Test Methods and Remarks
8	耐高温 High temperature resistance	①外观无可见损伤痕迹; No visible mechanical damage. ②感量变化不超过±5%; Inductance shall not change more than ±5%; ③FHD-UC series Q 值变化不超过±10%. FHD-UC series Q shall not change more than±10%.	①FHD-UC 系列产品放置于温度+125±5℃的环境 +24 中存放 1000—0 h FHD-UC series shall be subjected to +125±5℃ +24 for1000—0 h
9	温度冲击 Temperature Shock	①外观无可见损伤痕迹; No visible mechanical damage. ②感量变化不超过±5%; Inductance shall not change more than ±5%; ③FHD-UC series Q 值变化不超过±10%. FHD-UC series Q shall not change more than±10%.	①FHD-UC 系列: +125℃ 30 分钟 ↔ -40℃ 30 分钟, 循环 100 次; FHD-UC series : +125℃ 30minutes ↔ -40℃ 30minutes 100 Cycles.
10	高温负载 High temperature load	①外观无可见损伤痕迹; No visible mechanical damage. ②感量变化不超过±5%; Inductance shall not change more than ±5%; ③FHD-UC series Q 值变化不超过±10%. FHD-UC series Q shall not change more than±10%.	①FHD-UC 系列产品加额定电流在 125±2℃温度条 +24 件下存放 1000—0 h FHD-UC series shall be store at 125±2℃ for +24 1000—0 h with rated current applied.



序号 No.	项目 Items	要求 Requirements	试验方法及备注 Test Methods and Remarks
11	恒定湿热 Static Humidity	①外观无可见损伤痕迹; No visible mechanical damage. ②感量变化不超过±5%; Inductance shall not change more than ±5%; ③FHD-UC series Q 值变化不超过±10%。 FHD-UC series Q shall not change more than±10%.	将电感器放置在于湿度 90%~95%,温度 60±2℃的 +24 环境中存放 1000—0 h Inductors shall be subjected to 90%~95%RH. at +24 60±2℃ for 1000—0 h
12	抗弯强度 Bending strength	外观无可见损伤痕迹; No visible mechanical damage.	①将电感器安装于试验基板上; 在垂直方向施加力 (如下图所示)。Install the inductor on the test substrate; Apply force in the vertical direction (as shown below). ②该板应在 (1±0.5) mm/s 的弯曲速率向下弯曲 (2±0.2) mm, 保持时间 (20±1) s。The epoxy plate should bend down to (2±0.2) mm at the bending rate of (1±0.5) mm/s, Keep time (20±1) sec.
13	耐溶剂性 Solvent Resistance	①外观无可见损伤痕迹; No visible mechanical damage. ②感量变化不超过±5%; Inductance shall not change more than ±5%; ③FHD-UC series Q 值变化不超过±10%。 FHD-UC series Q shall not change more than±10%.	将元件浸泡在 23±5℃的异丙醇溶液中, 保持 5±0.5 分钟。 Soak in the element 23±5℃ in isopropyl alcohol solution, keep 5±0.5 min.

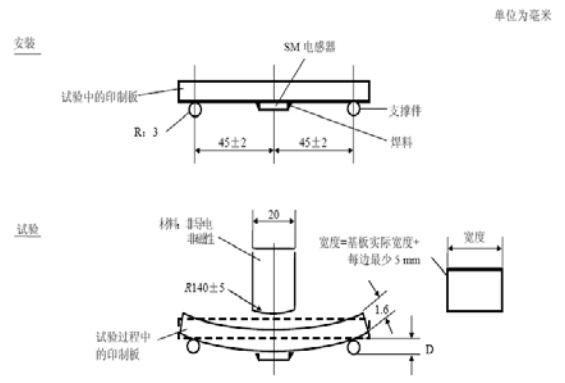

注: 以上要求测试电性能的项目, 在室温下放置至少 2 h 后在 48 h 内进行测试。

Note: When there are questions concerning, test within 48 h after placing at room temperature for at least 2 h.



5 产品包装 Packaging

1) 编带图 Taping drawings

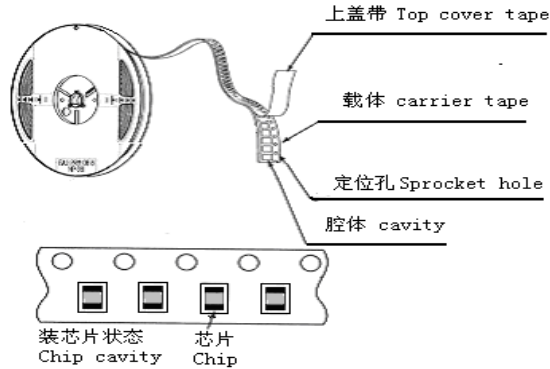

2) 卷盘尺寸 Reel dimensions (Unit: mm)

Part NO.	ΦA typ.	ΦB typ.	ΦC typ.	D typ.
0603	178	60	13	8.4

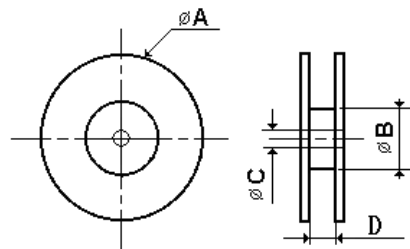

3) 导带及空格部分 Leader and blank portion

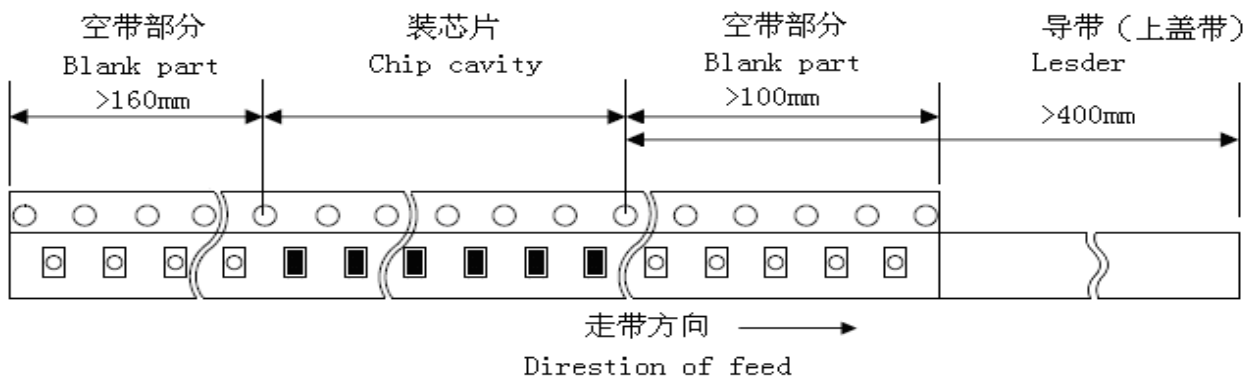

4) 编带尺寸 Taping dimensions (Unit: mm)

- 纸带 Paper tape

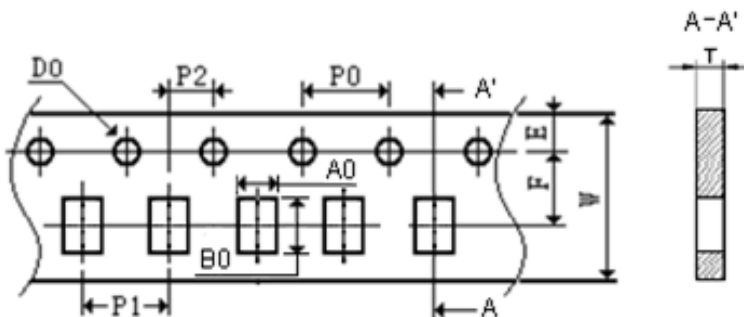



Part NO.	W	E	F	D0	P0	P1	P2	P0×10	A0	B0	T
0603	8.00	1.75	3.50	1.55	4	4	2	40	1.20	1.90	1.05

5) 剥离力检验 Peeling off force

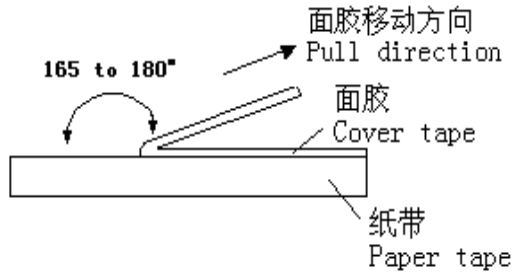

①盖带的剥离力要求 Peeling required

0603 系列 : 20 克~80 克 ;

0603 series : 20g~80g

②测试条件 Test condition

盖带剥离速度: 300mm/min±10%

Speed of peeling off : 300mm/min±10%

盖带剥离角度: 165° ~180°

Angle of peeling off: 165°~180°

6) 包装数量 (单位: 粒) Packaging number (Unit: Pcs)

类型 Size	0603	
每卷数量 Per Reel	4000	
每盒数量 Per Box	3 卷盒 3 Reel Per Box	12000
	5 卷盒 5 Reel Per Box	20000
每箱数量 Per Case	1.5 盒箱 1.5 Box Per Case	60000
	2 盒箱 2 Box Per Case	80000
	3 盒箱 3 Box Per Case	120000
	4 盒箱 4 Box Per Case	160000
	6 盒箱 6 Box Per Case	240000

7) 标签粘贴位置 Label stick station

卷盘标签 Reel label	纸盒标签 Carton label	纸盒标签 Carton label	外箱标签 Outer box label



6 推荐焊接条件 Recommend Soldering Conditions

1) 焊接条件 Soldering Conditions

本产品使用回流焊接法。

Applicable soldering process to the products is reflow soldering.

① 焊剂要求 Flux, Solder

- 使用松香基助焊剂，禁止使用卤化物含量超过 0.2(wt)%的强酸性助焊剂。
Don't use highly acidic flux with halide content exceeding 0.2(wt)%(chlorine conversion value).
- 使用无铅焊料 (96.5Sn /3.0Ag/0.5Cu)。
Using lead-free solder (96.5Sn /3.0Ag/0.5Cu).

② 焊接要求 Soldering conditions

- 预热时，产品表温与焊料温度的温差最大不允许超出 150℃，焊接完冷却时，产品表温与溶剂温度之间的温差最大不超过 100℃。预热不足有可能引发产品表面裂纹，从而导致产品品质下降。
Pre-heating should be in such a way that the temperature difference between solder and ferrite surface is limited to 150℃ max. Also cooling into solvent after soldering should be in such way that the temperature difference is limited to 100℃ max. Un-enough pre-heating may cause cracks on the ferrite, resulting in the deterioration of product quality.
- 产品要在以下画出的曲线允许的范围进行焊接。其它焊接条件可能引起产品电极的腐蚀。当焊接重复时，允许的时间为第一次做的累计时间。
Products should be soldered within the following allowable range indicated by the slanted line. The excessive soldering conditions may cause the corrosion of the electrode. When soldering is repeated, allowable time is the accumulated time.

2) 回流焊曲线 Reflow soldering profile

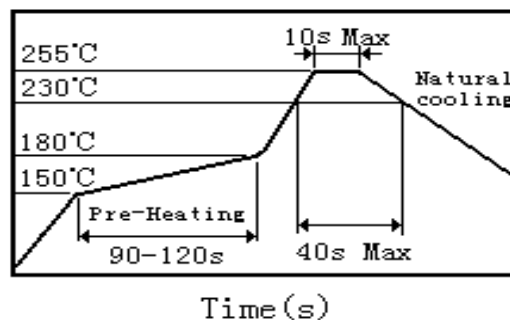

3) 手工焊接 Iron soldering

烙铁温度：350℃ (Max)

功率：最大为 30W

烙铁停留时间：<5S (注意不要将烙铁碰到产品线圈及包封层)。

Perform soldering at 350℃ on 30W max.

Soldering Time: < 5S (Take care not to apply the tip of the soldering iron to the terminal electrodes)。

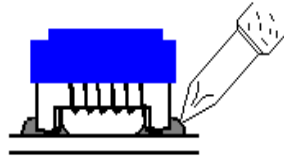

7 清洗 Cleaning

1) 清洗条件 Cleaning Conditions

- a. 清洗温度 : 60℃ (Max) Cleaning temperature : 60℃ max.
- b. 清洗时间 : 5 分钟 (Max) Cleaning time: 5 minutes Max.
- c. 超声波功率: 最大为 200W Ultrasonic output power: 200W max.

8 存储要求 Storage Requirements

1) 存储期限 Storage period

距电感公司出厂检验时间 1 年内, 产品可以使用检验时间可以通过包装外侧标记的检验号确认。若时间超过 1 年, 应检查焊接性能后方可使用。

Products which inspected inductor company over 1 year ago should be examined and used, which can be Confirmed with inspection No. marked on the container. Solder ability should be checked if this period is exceeded.

2) 存储条件 Storage conditions

- (1) 存放货物的库房应满足以下条件: 温度: -10 ~ +40℃, 相对湿度: 30 ~ 70%。
- (2) 禁止将产品保管在腐蚀性物质中, 如硫磺、氯气或酸, 否则将引起端头氧化, 导致降低焊接性。
- (3) 为了避免受潮气、灰尘等物质的影响, 产品应保管于货架上。
- (4) 产品保管在库房中, 应避免热冲击、振动以及直接光照等等。
- (5) 产品应密封包装。

(1) Products should be storage in the warehouse on the following conditions:

Temperature : -10~+40℃ Humidity: 30~70% relative humidity

- (2) Don't keep products in corrosive gases such as sulfur, chlorine gas or acid , or it may case oxidization of Electrodes resulting in poor solder ability.
- (3) Products should be stored on the palette for the prevention of the influence from humidity, dust and so on.
- (4) Products should be stored in the warehouse without heat shock, vibration, direct sunlight and so on.
- (5) Products should be stored under the airtight packaged condition.

9 ODS (消耗臭氧层物质) 的使用情况 Usage Of ODS

对于以下所列物质, 我公司在生产过程中绝不使用。

ODS: CCl₄ (四氯化碳)、HCFC 等。

For ODS listed below , we don't use in process.



ODS: CCl₄, HCFC, etc.

10 注意事项 Notes

(1) RoHS 指令 Response to RoHS directive

本公司产品符合 RoHS 指令。

Our products are RoHS compliance.

(2) 本承认书保证我司产品作为一个单体时的质量情况，当我司产品被安装到贵司产品上时请保证贵司的产品已根据贵司的规范进行了有效评价和确认。

This product specification guarantees the quality of our product as a single unit, Please make sure that your product has been evaluated and confirmed against your specifications when our product is mounted to your product.

(3) 如果贵司对我司产品的试用已超过了本测试规范所界定的产品功能，对于此所引发的失效我司将不予保证。

We can't warrant against failure caused by any use of our product that deviates from the intended use as described in this product specification.

(4) 为防止断线，请不要使用锋利的物体接触线圈，如镊子。

Do not touch wire with sharp objects such as tweezers to prevent wire breakage.